

06

Rotulplan

ES| Sistemas de rotulación
GB| Signs systems
FR| Systèmes de signalétique
DE| Beschilderungssysteme
IT| Sistemi segnaletici
PO| Sistemas de sinalização



ES| Sistemas de rotulación

La señalización disponible en todas sus modalidades de soportes bajo la familia ROTULPLAN, es el elemento de comunicación por excelencia tanto de espacios públicos como privados. Perfil plano, curvo, sistema de cristal, de aluminio / cristal y de inox,... son los soportes que tenemos a su disposición para una buena comunicación, direccionamiento e identificación de las estancias o zonas en cualquier empresa, almacén, espacio público, ayuntamientos, museos, hospitales, etc...



GB| Signs systems

It is indispensable to indicate and guide people. It is the element of communication by excellence for public areas as well as private ones. This family proposes different and various possibilities of form, colour, writing style, and texts to realize any types of signs. We have a large range of glass, aluminium, and inox supports to make planed and curved sign systems to realize a good communication and information in areas and zones of companies, stores or public areas such as town halls, museums, hospitals, etc...





FR | Systèmes de signalétique

Il est indispensable de signaler et orienter le sens de circulation des espaces publics ou privés à l'intérieur et extérieur des bâtiments. Cette famille de produit est adaptée à tous vos besoins et pour tous les goûts. Nous travaillons sur des supports en verre, en aluminium plan ou courbe et en inox découpé au laser afin de proposer une gamme ample pour des solutions complètes pour équiper les hôpitaux, écoles, universités, bureaux, banques...



IT | Sistemi segnaletici

E' indispensabile segnalare e guidare le persone. Questo è un elemento di comunicazione per eccellenza per aree pubbliche e private allo stesso tempo. Questa famiglia propone diversi tipi di possibilità di forme, colori... per realizzare qualsiasi segnaletica. Abbiamo una ampia gamma di supporti in vetro, alluminio ed inox per realizzare segnaletica curva o piana in modo tale da avere una buona comunicazione ed informazione in aree e zone diverse per aziende, negozi, aree pubbliche come municipi, musei, ospedali, ecc.



DE | Beschilderungssysteme

Die Familie der Produkte VISUAL PLAN schließt eine umfangreiche Produktpalette ein, die an die Visuelle Kommunikation Gruppe gerichtet werden. Whiteboards in einem ausgedehnten Produktportfolio und Qualitäten umfaßt die vollständigen Marktbranchen und reicht von Firmen home/office bis zur Hotel-geschäfte und Schulaktivitäten. Büros, Ausbildungsräume, Konferenzzimmer, Universitäten und Schulen sind die Hauptziele dieser Familie der Produkte.



PO | Sistemas de sinalização

A sinalética disponível em todas as suas modalidades de suportes na família ROTULPLAN, são o elemento de comunicação por excelência tanto de espaços públicos como privados. Perfil plano, curvo, sistema de vidro, de alumínio/vidro e de inox, são os suportes que temos à sua disposição para uma boa comunicação, direcção e identificação dos espaços ou zonas em qualquer empresa, armazém ou espaço público (câmaras, museus, hospitais, etc...)

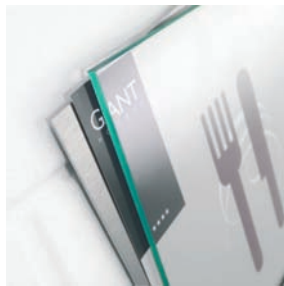



268

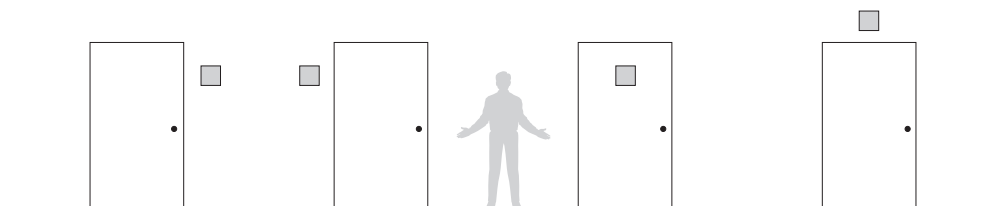
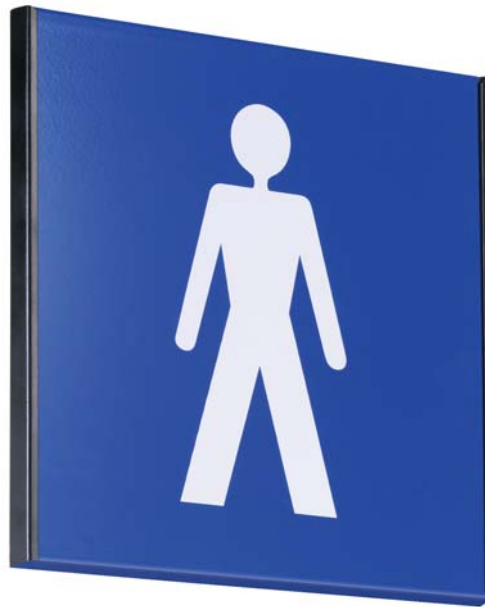

ES | Pictogramas

Pictograma mural con silueta de vinilo en color blanco o negro, fabricado con perfil de aluminio lacado disponible en 14 colores standard y 4 tamaños distintos 12 x 12, 16 x 16, 12 x 24 y 16 x 32 cm. Las fijaciones laterales son metálicas pintadas en negro.

GB | Pictogram

Aluminium wall pictogram with white or black pictures and 14 different colour backdrops. Available in 4 sizes 12 x 12, 16 x 16, 12 x 24 and 16 x 32 cm. End caps are painted in black. Fixed to the wall through screws and optionally through double face adhesive.

FR | Pictogramme

Pictogramme mural sur profil en aluminium laqué avec marquage en vinyle blanc ou noir. Disponible en 4 formats 12 x 12, 16 x 16, 12 x 24 et 16 x 32 cm. et plaques en 14 couleurs standard. Les fixations latérales sont métalliques coloris noir. Option adhesif.

DE | Piktogrammen

Piktogrammen mit lackiertem Aluminiumrahmen und weißer oder schwarzer Vinyl-Markierung. Die Systemprofile ermöglichen eine einfache Montage. Verfügbar in 4 Formaten 12 x 12, 16 x 16, 12 x 24 und 16 x 32 cm. und die Platten in 14 Standardfarben.

IT | Pittogramma

Pittogramma a muro fatto in alluminio con figure in bianco o nero e 14 differenti colori di listelli. Disponibile in 4 formati 12 x 12, 16 x 16, 12 x 24 e 16 x 32 cm. I tappi finali in metallo sono neri. Fissabile a muro con viti o biadesivo.

PO | Pictograma

Pictograma de parede com silhueta em vinil na cor branca ou preta, fabricado em perfil de alumínio lacado, disponível em 14 cores standard e 4 tamanhos diferentes 12 x 12, 16 x 16, 24 x 24 e 16 x 32 cm. Os encaixes laterais são em metal pintado na cor preta.

A mural

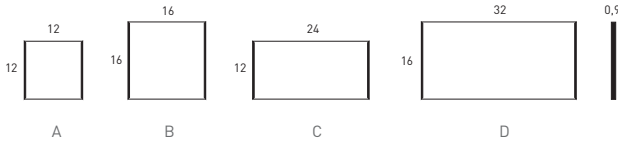

A	788/M/12	12 x 12	0,9	
B	788/M/16	16 x 16	0,9	
C	788/M/24	12 x 24	0,9	
D	788/M/32	16 x 32	0,9	
				1
				AD/12
				2 x 12
				AD/16
				2 x 16



B proyectado

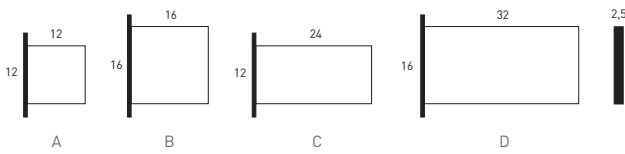

A	788/P/12	12 x 12	2,5
B	788/P/16	16 x 16	2,5
C	788/P/24	12 x 24	2,5
D	788/P/32	16 x 32	2,5



- 1 Aseos caballero
Men toilets
- 2 Aseos señora
Women toilets
- 3 Aseos
Toilets/restroom
- 4 Restaurante
Restaurant
- 5 Cafetería
Coffee shop
- 6 Teléfono
Telephone
- 7 Información
Information

- 8 Guardarropa
Cloakroom
- 9 No pasar
Do not cross
- 10 No fumar
No smoking
- 11 Flecha
Arrow
- 13 Ascensor
Lift
- 14 Minusválido
Disable
- 15 S. Reuniones
Meeting room

- 16 Subida esc.
Up stairs
- 18 Bajada esc.
Down stairs
- 20 Sala espera
Waiting room
- 21 Salida
Way out
- 22 Entrada
Way in
- 24 Limpieza
Cleaning room
- 25 Correos
Post office

- 36 Ducha
Shower
- 37 Piscina
Swimming pool
- 39 Vest. Masculino
Men Chan. room
- 40 Vest. Femenino
Wom. Chan. room
- 41 Peluquería
Hairdresser
- 42 Oficina
Office
- 44 Consigna
Lockers

- 45 Recepción
Reception
- 47 Sala TV.
TV room
- 48 Serv. Médicos
Medical facil.
- 49 Hospital
Hospital
- 50 Silencio
Silence
- 51 Punto de enc.
Meeting point
- 52 Biblioteca
Library

- 54 Esc. Mecán.
Escalator
- 60 Fumadores
Smoking room
- 61 Animales no
No anim. entry
- 64 Enfermería
Infirmary
- 69 Basuras no
Rubbish bin
- 74 Fotos no
No cameras
- 164 Móviles no
No mobile phones

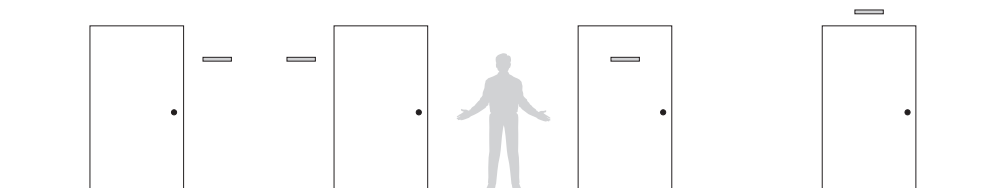
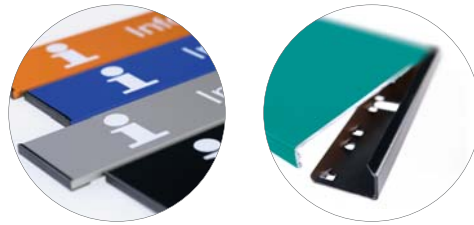

ES | Rótulos murales margen puerta

Rótulo mural margen puerta de aluminio lacado, de texto fijo en vinilo de color blanco o negro. Disponible en 4 medidas de altura, 4, 8, 12 y 16 cm. y 14 colores standard. Se aplican sobre la pared mediante tornillos u opcionalmente con adhesivo doble cara.

GB | Wall signs (door frames)

Aluminium wall signs for door frames with white or black letters and 14 different coloured backdrops. Available in 4 distinct sizes with heights of 4, 8, 12 and 16 cm. respectively. Mount any wall sign with screws or adhesives.

FR | Signalétique murale

Signalétique murale sur profil en aluminium laqué avec marquage en vinyle blanc ou noir. Disponible en 4 formats 4, 8, 12, et 16 cm. de haut et 14 coloris standard. Fixation par vis sous la plaque ou optionnellement par adhésif double face.

DE | Türschilder

Türschilder mit lackiertem Aluminiumrahmen und weißer oder schwarzer Vinyl-Markierung. Die Systemprofile ermöglichen eine einfache Montage. Verfügbar in 4 Formaten 4, 8, 12 und 16 cm. und die Platten in 14 Standardfarben. Die Profil ist schwarz.

IT | Segnaletica a muro fuoriporta

Segnaletica a muro fuoriporta con lettere bianche o nere e 14 differenti colori standard. Disponibile in 4 diversi formati con altezze da 4, 8, 12 e 16 cm. Segnaletica montabile con viti o biadesivo. Si possono aggiungere pittogrammi e frecce in base alle Vs. esigenze.

PO | Sinalética de porta

Sinalética de porta em alumínio lacado, com texto fixo em vinil na cor preta ou branca. Disponível com 4, 8, 12 e 16 cm. de altura e 14 cores standard. É aplicada mediante parafusos ou opcionalmente com adesivo de dupla face.

A

rótulos

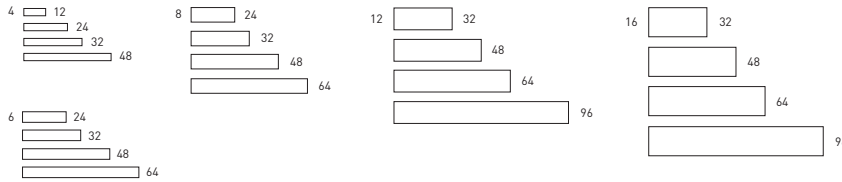

Información

		texto text	ABC...
789/4/12/M	4 x 12	2	8 / 10
789/4/24/M	4 x 24	2	12 / 14
789/4/32/M	4 x 32	2	18 / 20
789/4/48/M	4 x 48	2	24 / 26
789/6/24/M	6 x 24	2,6	8 / 10
789/6/32/M	6 x 32	2,6	12 / 14
789/6/48/M	6 x 48	2,6	18 / 20
789/6/64/M	6 x 64	2,6	24 / 26

		texto text	ABC...
789/8/24/M	8 x 24	3,2	8 / 10
789/8/32/M	8 x 32	3,2	12 / 14
789/8/48/M	8 x 48	3,2	18 / 20
789/8/64/M	8 x 64	3,2	24 / 26
789/12/32/M	12 x 32	4,8	8 / 10
789/12/48/M	12 x 48	4,8	12 / 14
789/12/64/M	12 x 64	4,8	18 / 20
789/12/96/M	12 x 96	4,8	24 / 26

		texto text	ABC...
789/16/32/M	16 x 32	6,4	6 / 8
789/16/48/M	16 x 48	6,4	8 / 10
789/16/64/M	16 x 64	6,4	12 / 14
789/16/96/M	16 x 96	6,4	18 / 20

B

subrayado



Información

Información

LS/1/12/M	1 x 12	0,9
* LS/1/24/M	1 x 24	0,9
LS/1/32/M	1 x 32	0,9
LS/1/48/M	1 x 48	0,9
LS/1/64/M	1 x 64	0,9
LS/1/96/M	1 x 96	0,9

LS/2/12/M	2 x 12	0,9
* * LS/2/24/M	2 x 24	0,9
LS/2/32/M	2 x 32	0,9
LS/2/48/M	2 x 48	0,9
LS/2/64/M	2 x 64	0,9
LS/2/96/M	2 x 96	0,9

* LS/1/24/M

** LS/2/24/M

C

texto

- ES - Línea de texto adicional
- GB - Additional text line
- FR - Ligne de texte additionnelle
- DE - Textlinien hinzufügen
- IT - Testo supplementare
- PO - Linhas de texto adicional

Información
* TA/24

* TA/24	24
TA/32	32
TA/48	48
TA/64	64
TA/96	96

D

adhesivo



- * Adhesivo doble cara opcional
- * Optional double face adhesive

AD/4	4 x 2
AD/8	8 x 2
AD/12	12 x 2
AD/16	16 x 2



E

sobremesa

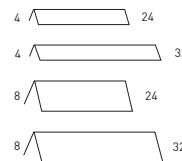

789/4/24/SB	4 x 24	0,9
789/4/32/SB	4 x 32	0,9
789/8/24/SB	8 x 24	0,9
789/8/32/SB	8 x 32	0,9



272



A	↖	↗
789/8/24/P	8 x 24	2,5
789/8/32/P	8 x 32	2,5
789/8/48/P	8 x 48	2,5
B		
789/12/24/P	12 x 24	2,5
789/12/32/P	12 x 32	2,5
789/12/48/P	12 x 48	2,5
C		
789/16/24/P	16 x 24	2,5
789/16/32/P	16 x 32	2,5
789/16/48/P	16 x 48	2,5

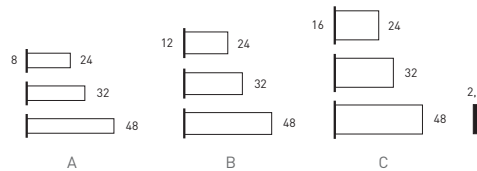

1	↖	↗
LS/1/24/P	1 x 24	2,5
LS/1/32/P	1 x 32	2,5
LS/1/48/P	1 x 48	2,5
2		
LS/2/24/P	2 x 24	2,5
LS/2/32/P	2 x 32	2,5
LS/2/48/P	2 x 48	2,5

ES | Rótulo proyectado

Rótulo proyectado doble cara de aluminio lacado, de texto fijo en vinilo de color blanco o negro. Disponible en 3 medidas de altura, 8, 12 y 16 cm. Se aplican sobre la pared mediante tornillos.

FR | Signalétique en drapeau

Signalétique en drapeau sur profil en aluminium laqué avec marquage en vinyle blanc ou noir. Disponible en 3 formats 8, 12 et 16 cm. de haut. Fixation par vis sur la plaque.

IT | Segnaletica a bandiera

Pittogramma bifacciale a bandiera con figure in bianco o nero e 14 differenti colori di listelli. Disponibile in 4 formati 12 x 12, 16 x 16, 12 x 24 e 16 x 32 cm. I tappi finali in metallo sono neri. Fissabile a muro con viti.

GB | Flag signs

Aluminium double sided flag wall signs with white or black letters. Available in 3 distinct sizes with heights of 8, 12 and 16 cm. and lengths of 24, 32 and 48 cm. respectively. Mount any projected wall sign with screws.

DE | Fahnschilder

Schilder mit lackiertem Aluminiumrahmen und weißer oder schwarzer Vinyl-Markierung. Die Systemprofile ermöglichen eine einfache Montage. Verfügbar in 3 Hoch Formaten 8, 12 und 16 cm. Befestigung durch Schraube oder nach Wahl.

PO | Sinalética projectada

Sinalética projectada de dupla face em alumínio lacado, com texto fixo em vinil na cor preta ou branca. Disponível com 8, 12 e 16 cm. de altura. É aplicada mediante parafusos.



PLANO

PS design

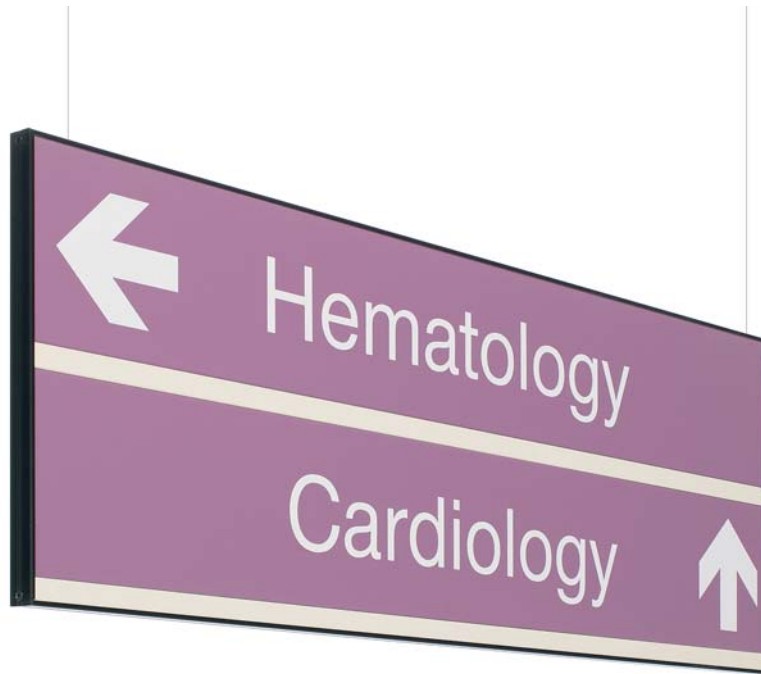

Model	Dimensions (H x W)	Depth
A		
789/8/48/S	8 x 48	2,5
789/8/64/S	8 x 64	2,5
789/8/96/S	8 x 96	2,5
B		
789/12/48/S	12 x 48	2,5
789/12/64/S	12 x 64	2,5
789/12/96/S	12 x 96	2,5
C		
789/16/48/S	16 x 48	2,5
789/16/64/S	16 x 64	2,5
789/16/96/S	16 x 96	2,5
1		
LS/1/48/S	1 x 48	2,5
LS/1/64/S	1 x 64	2,5
LS/1/96/S	1 x 96	2,5
2		
LS/2/48/S	2 x 48	2,5
LS/2/64/S	2 x 64	2,5
LS/2/96/S	2 x 96	2,5

ES | Rótulo suspendido

Rótulo suspendido doble cara de aluminio lacado, de texto fijo en vinilo de color blanco o negro. Disponible en 3 medidas de altura, 8, 12 y 16 cm. Se suspenden del techo mediante cable de nylon (incluido). Estas señales se colocan en pasillos y accesos.

FR | Signalétique suspendu

Signalétique suspendu sur profil en aluminium laqué avec marquage en vinyle blanc ou noir. Disponible en 3 formats 8, 12, et 16 cm. de hauteur. Suspendus au plafond par un câble de nylon (inclus).

IT | Targa sospesa bifacciale

Targa in alluminio sospesa con lettere bianche o nere e 14 listelli in colori diversi. Disponibile in 3 misure diverse con altezze 8, 12 e 16 cm. La segnaletica sospesa comprende il cavo di nylon e le informazioni possono essere inserite in più linee e in modo bifacciale.

GB | Suspended signs

Aluminium suspended signs with white or black letters and 14 different colored backdrops. Available in 3 distinct sizes with heights of 8, 12 and 16 cm. Suspend sign with included nylon string.

DE | Deckenabhängend- Reschriftung

Deckenabhängend-Beschriftung mit lackiertem Aluminiumrahmen und weißer oder schwarzer Vinyl- Markierung. Die Systemprofile ermöglichen eine einfache Montage. Sie werden an der Decke auf einem Nylon-Seile (eingeschlossen) aufgehängt.

PO | Sinalética suspensa

Sinalética suspensa de dupla face em alumínio lacado, com texto fixo em vinil na cor preta ou branca. Disponível com 8, 12 e 16 cm. de altura. É suspensa no tecto através de cabo de nylon (incluído). Esta sinalética pode ser colocada em corredores e acessos.



2
Marketing
Administration
1
R+d
Laboratory
0
Cafeteria
Reception

GANT HOTEL	
1 Information	→
2 Rooms	↑
3 Pool	→
4 Gymnasium	←
1	2
3	4

High School	
Classroom 1-10	→
Classroom 11-20	→
Classroom 21-30	↑
Classroom 31-40	↑
Information	→
Gymnasium	→
Toilets	←

SPORT	
Gymnasium	→
Cafeteria	→
Natatorium	←
Toilets	→
Fitness Center	←
Tennis Courts	←

3	UCI
	Administration
2	Oncology
	Endoscopy
1	Medical Imaging
	Volunter Services
0	Main Entrance
	Administration
	Waitign Room

ES | Directorios murales

Directorio formado por laminas de aluminio lacado, de texto fijo en vinilo de color blanco o negro. Disponible en 6 medidas de altura, 1, 2, 4, 6, 8, 12 y 16 cm. Disponible en 14 colores.

FR | Multi-plaques

Directoire multi plaques sur profil en aluminium laqué avec lettres blanches ou noires et 14 coloris standard. Disponible en 6 formats 1, 2, 4, 6, 8, 12 et 16 cm. de haut.

IT | Lama per segnaletica direzionale a muro

Segnaletica a muro direzionale con lettere nere o bianche. Disponibile in 6 misure diverse con altezze 1, 2, 4, 6, 8, 12 e 16 cm. Da mettere nei corridoi e nelle entrate per orientare i visitatori.

GB | Directional signs

Lacquered aluminium mini directories with white or black letters and 14 different colour backdrops. Available in 6 distinct sizes with heights of 1, 2, 4, 6, 8, 12 and 16 cm.

DE | Wegweisersystem

Wegweisersystem mit lackiertem Aluminiumrahmen und weißer oder schwarzer Vinyl-Markierung. Das flexible System läßt viele Möglichkeiten zu. Verfügbar in 6 Höhenformaten 1, 2, 4, 6, 8, 12 und 16 cm.

PO | Directório de parede

Directório formado por perfis em alumínio lacado, com texto fixo em vinil na cor preta ou branca. Disponível com 1, 2, 4, 6, 8, 12 e 16 cm. de altura. Esta sinalética deve ser visível na entrada de edifícios e permite orientar e direccionar o fluxo de pessoas.

A

laminas

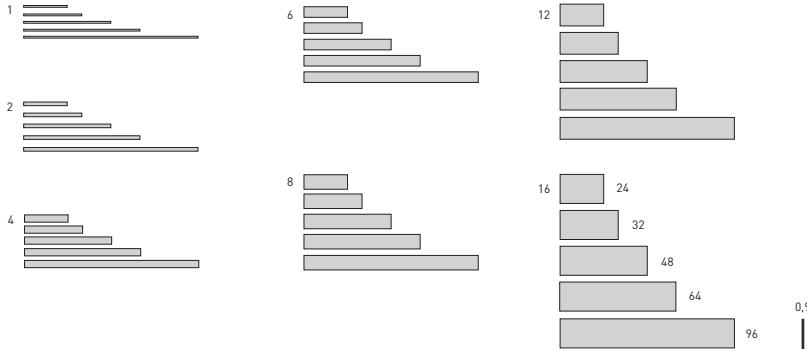

		texto text	ABC...
790/1/24/D	1 x 24	-	-
790/1/32/D	1 x 32	-	-
790/1/48/D	1 x 48	-	-
790/1/64/D	1 x 64	-	-
790/1/96/D	1 x 96	-	-
790/2/24/D	2 x 24	-	-
790/2/32/D	2 x 32	-	-
790/2/48/D	2 x 48	-	-
790/2/64/D	2 x 64	-	-
790/2/96/D	2 x 96	-	-
790/4/24/D	4 x 24	2	12 / 20
790/4/32/D	4 x 32	2	18 / 24
790/4/48/D	4 x 48	2	24 / 26
790/4/64/D	4 x 64	2	36 / 38
790/4/96/D	4 x 96	2	60 / 62
790/6/24/D	6 x 24	2	10 / 18
790/6/32/D	6 x 32	2	14 / 16
790/6/48/D	6 x 48	2	20 / 24
790/6/64/D	6 x 64	2	30 / 36
790/6/96/D	6 x 96	2	40 / 48

		texto text	ABC...
790/8/24/D	8 x 24	3,2	8 / 10
790/8/32/D	8 x 32	3,2	12 / 14
790/8/48/D	8 x 48	3,2	16 / 18
790/8/64/D	8 x 64	3,2	24 / 26
790/8/96/D	8 x 96	3,2	36 / 38
790/12/24/D	12 x 24	4,8	6 / 8
790/12/32/D	12 x 32	4,8	8 / 10
790/12/48/D	12 x 48	4,8	12 / 14
790/12/64/D	12 x 64	4,8	18 / 20
790/12/96/D	12 x 96	4,8	24 / 26
790/16/24/D	16 x 24	6,4	4 / 6
790/16/32/D	16 x 32	6,4	6 / 8
790/16/48/D	16 x 48	6,4	8 / 10
790/16/64/D	16 x 64	6,4	12 / 24
790/16/96/D	16 x 96	6,4	18 / 20

275



B

texto

- ES - Línea de texto adicional
- GB - Additional text line
- FR - Ligne de texte additionnelle
- DE - Textlinien hinzufügen
- IT - Testo supplementare
- PO - Linhas de texto adicional

TA/24	24
TA/32	32
TA/48	48
* TA/64	64
TA/96	96



C

planos

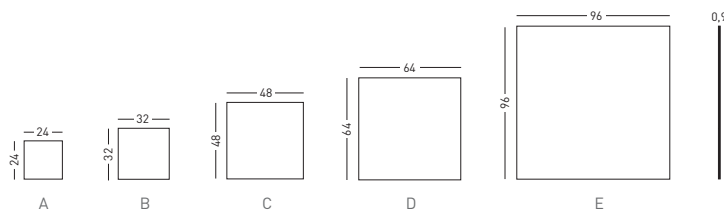

A 790/PD/24	24 x 24	0,9
B 790/PD/32	32 x 32	0,9
C 790/PD/48	48 x 48	0,9
* D 790/PD/64	64 x 64	0,9
E 790/PD/96	96 x 96	0,9

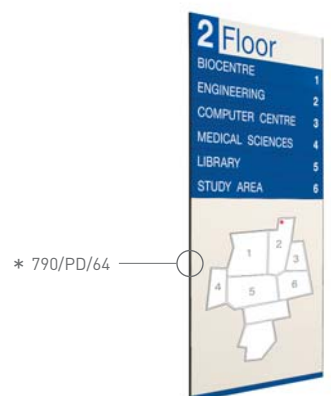



276

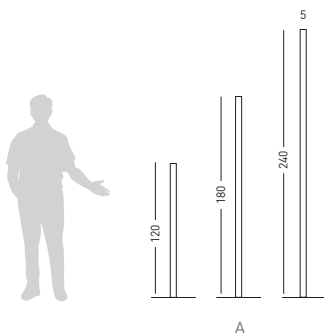

A		B	
790/TP/120	120	8 x 24	2,5
790/TP/180	180	8 x 32	2,5
790/TP/240	240	8 x 48	2,5

B	
789/8/24/P	8 x 24
789/8/32/P	8 x 32
789/8/48/P	8 x 48
789/12/24/P	12 x 24
789/12/32/P	12 x 32
789/12/48/P	12 x 48
789/16/24/P	16 x 24
789/16/32/P	16 x 32
789/16/48/P	16 x 48

ES | Poste para rótulos proyectados

Poste de aluminio con base metálica para situar en áreas interiores, para indicar al personal las posibles diversas direcciones a seguir dentro de un edificio. Los rótulos pueden situarse en cualquiera de los 4 lados del perfil y disponibles en varios tamaños y colores.

FR | Poteaux pour signalétique en drapeau

Poteaux en aluminium. Pour assembler plusieurs éléments de signalétique. Base métallique. 3 hauteurs disponibles. Pour usage intérieur.

IT | Palo per sistemare etichette progettate

Colonnina in alluminio con base metallica per interni. Le etichette, disponibili in vari temi e colori, possono essere collocate in uno qualsiasi dei 4 lati.

GB | Aluminium post for flag signs

Aluminium posts to assemble different signs. Metallic base. 3 heights available. Indoor use ideal in a hall pointing the in directions.

DE | Aluminium-Ständer mit Metallfuß

Aluminium-Ständer mit Metallfuß für den Innenbereich. Die Beschilderungen können in jeder der vier Seiten des Profils und sind in verschiedenen Größen und Farben erhältlich

PO | Poste para colocar sinalética projectada

Poste em alumínio com base metálica para colocar em áreas interiores. A sinalética pode ser colocada em qualquer dos 4 lados do perfil e está disponível em vários tamanhos e cores.

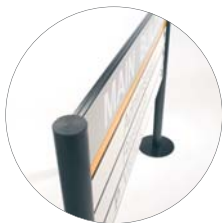

PLANO

PS design



A	↖ ↗	▶◀
790/T/120	120	∅ 7
790/T/180	180	∅ 7
790/T/240	240	∅ 7
B		
790/12/96/T	12 x 96	2,5
790/12/144/T	12 x 144	2,5
790/16/96/T	16 x 96	2,5
790/16/144/T	16 x 144	2,5
C		
790/PD/96/T	96 x 96	2,5
790/PD/144/T	96 x 144	2,5

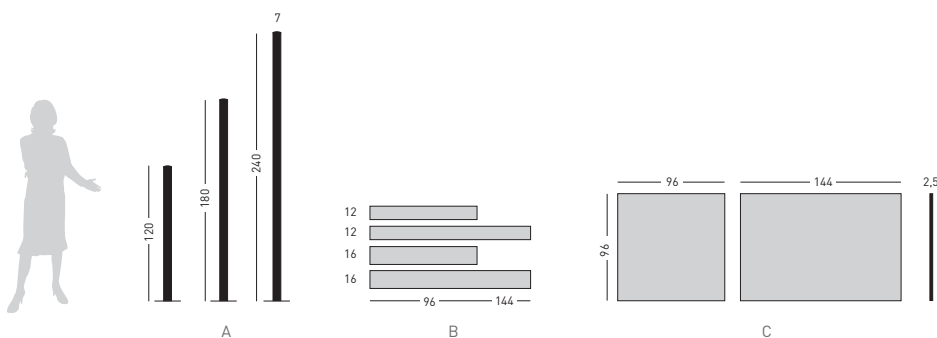

ES | Rótulo para exterior

Rótulo instalado en la parte exterior de los edificios para la orientación, señalización y situación de diferentes lugares exteriores como zonas de entrada, almacenes, p rkings, parques tem ticos, etc. y para ubicaci n de lugares en el interior del edificio.

GB | Outdoor signs

Signs placed in the outer part of the buildings for the direction, signalling and situation of different outer places like zones from entrance, warehouses, p rkings, thematic parks, etc. and for location of places in the interior of the buildings. Post, bar and panel system.

FR | Signal tique ext rieure

Directoire multi plaques sur profil en aluminium laqu  avec lettres blanches ou noires et 14 coloris standard. Disponible en 6 formats 1, 2, 4, 8, 12 et 16 cm. de haut. Placez les multi plaques sur poteaux pour ext rieur comme parking, all , etc...

DE | Schilder f r Au enbereich

Schilder f r Au enbereich. Einfache Montage und Witterungsfester robuster Aluminiumstand. Die Systemprofile erm glichen eine einfache Montage und garantieren einen sicheren Stand. Auswechselbare Beschriftungsprofile.

IT | Segnaletica esterna

Segnaletica da esterno per direzionare e segnalare zone come ingressi, magazzini, parcheggi, parchi a tema, ecc. Consistono in uno o due robusti pali di alluminio fissati a terra.

PO | Sinal tica para exterior

Sinal tica instalada no exterior dos edif cios para a orienta o, sinaliza o e localiza o de diferentes locais exteriores, como zonas de entrada, armaz ns, estacionamento, parques tem ticos, etc., e para localiza o de locais no interior dos edif cios.

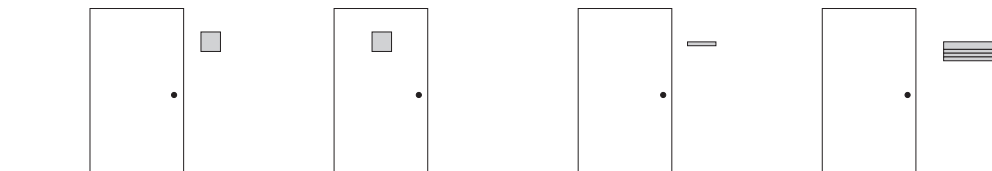

ES | Pictogramas y rótulos en "Braille"

Pictograma en alto relieve y braille mural con silueta de vinilo en color blanco o negro, fabricado con perfil de aluminio lacado disponible en 14 colores standard y 4 tamaños distintos 12x12, 16x16, 12x24 y 16x32 cm. Las fijaciones laterales son metálicas pintadas en negro.

FR | Pictogramme haut relief et "Braille"

Pictogramme en haut relief et braille de couleur noire, en aluminium laqué. Disponible en 14 couleurs et 4 dimensions. Les fixations latérales sont métalliques et peintes en noir. Mural ou en drapeau.

IT | Pittogramma in alto rilievo e "Braille"

Pittogramma in alto rilievo e braille con sagoma di colore nero, fabbricata con cornice in alluminio laccato disponibile in 14 colori standard e formati distinti 12x12, 16x16, 12x24 e 16x32 cm. I fissaggi laterale sono in matella dipinto di nero.

GB | Pictogram high-relief and "Braille"

Laquered aluminium pictogram in black high-relief and Braille. Available in 14 colors and 4 dimensions, wall or flag version. Black metallic side fixations.

DE | Piktogrammen "Braille"

Piktogrammen und Beschilderungen "Braille". Piktogramm in Hochrelief und Wand-Braille mit weißer oder schwarzer Vinyl-Silhouette. Hergestellt in lackiertem Alu-Profil. Die Seitenbefestigen sind metallisch und schwarz gestrichen.

PO | Pictograma em alto relevo e "Braille"

Pictograma em alto relevo e Braille, fabricado com perfil em alumínio lacado. Está disponível em 14 cores standard e 4 tamanhos diferentes: 12x12, 16x16, 12x24 e 16x32 cm. O acabamento lateral é metálico pintando a preto.

A

picto

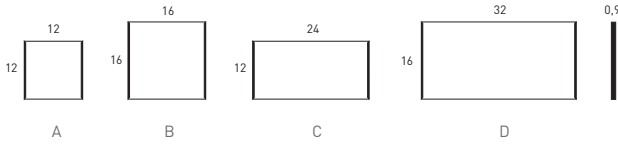

A	788/M/12/BLL	12 x 12	0,9
B	788/M/16/BLL	16 x 16	0,9
C	788/M/24/BLL	12 x 24	0,9
D	788/M/32/BLL	16 x 32	0,9

1	AD/12	2 x 12
	AD/16	2 x 16



B

rótulo

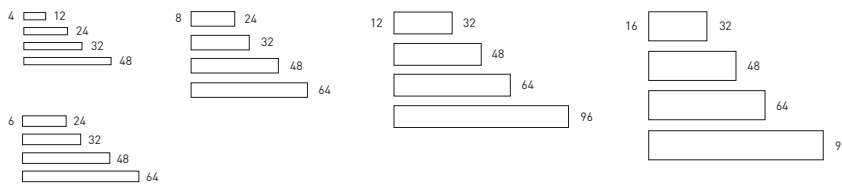

789/4/12/M/BLL	4 x 12	2
789/4/24/M/BLL	4 x 24	2
789/4/32/M/BLL	4 x 32	2
789/4/48/M/BLL	4 x 48	2

789/6/24/M/BLL	6 x 24	2,6
789/6/32/M/BLL	6 x 32	2,6
789/6/48/M/BLL	6 x 48	2,6
789/6/64/M/BLL	6 x 64	2,6

789/8/24/M/BLL	8 x 24	3,2
789/8/32/M/BLL	8 x 32	3,2
789/8/48/M/BLL	8 x 48	3,2
789/8/64/M/BLL	8 x 64	3,2

789/12/32/M/BLL	12 x 32	4,8
789/12/48/M/BLL	12 x 48	4,8
789/12/64/M/BLL	12 x 64	4,8
789/12/96/M/BLL	12 x 96	4,8

789/16/32/M/BLL	16 x 32	6,4
789/16/48/M/BLL	16 x 48	6,4
789/16/64/M/BLL	16 x 64	6,4
789/16/96/M/BLL	16 x 96	6,4



- | | | | | | |
|----------------------------------|---------------------------------|--------------------------------|--------------------------------------|------------------------------------|------------------------------------|
| 1 Aseos caballero
Men toilets | 8 Guardarropa
Cloakroom | 16 Subida esc.
Up stairs | 36 Ducha
Shower | 45 Recepción
Reception | 54 Esc. Mecán.
Escalator |
| 2 Aseos señora
Women toilets | 9 No pasar
Do not cross | 18 Bajada esc.
Down stairs | 37 Piscina
Swimming pool | 47 Sala TV.
TV room | 60 Fumadores
Smoking room |
| 3 Aseos
Toilets/restroom | 10 No fumar
No smoking | 20 Sala espera
Waiting room | 39 Vest. Masculino
Men Chan. room | 48 Serv. Médicos
Medical facil. | 61 Animales no
No anim. entry |
| 4 Restaurante
Restaurant | 11 Flecha
Arrow | 21 Salida
Way out | 40 Vest. Femenino
Wom. Chan. room | 49 Hospital
Hospital | 64 Enfermería
Infirmary |
| 5 Cafeteria
Coffee shop | 13 Ascensor
Lift | 22 Entrada
Way in | 41 Peluquería
Hairdresser | 50 Silencio
Silence | 69 Basuras no
Rubbish bin |
| 6 Teléfono
Telephone | 14 Minusválido
Disable | 24 Limpieza
Cleaning room | 42 Oficina
Office | 51 Punto de enc.
Meeting point | 74 Fotos no
No cameras |
| 7 Información
Information | 15 S. Reuniones
Meeting room | 25 Correos
Post office | 44 Consigna
Lockers | 52 Biblioteca
Library | 164 Móviles no
No mobile phones |



CURVO

PS design

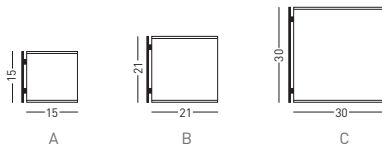

A	793/P/15	15 x 15	2,4
B	793/P/21	21 x 21	2,8
C	793/P/30	30 x 30	3,6

ES | Pictograma proyectado perfil curvo

Rótulo de perfil curvo para pictogramas proyectados (doble cara). Está fabricado con perfil de aluminio anodizado en color plata mate. El soporte permite la incorporación del papel (pictograma o texto). Mediante una ventosa se puede levantar el plástico protector.

GB | Curved profile double sided flag pictogram

Curved profile double sided flag pictos with for wall pictograms made with silver anodised aluminium frame. The support allows you to add paper with pictograms or text. With suction cup pull off transparent sleeve. Place on the wall with screws.

FR | Pictogramme en drapeau profil courbe

Profil mural en aluminium anodisé convexe pour signalétique ou pictogrammes. L'incorporation de l'information papier (picto ou texte) est facile. Grâce à une ventouse on enlève le plastique transparent qui protège le support et on insère le texte.

DE | Gewölbtes-profil wandabstehend

Wandabstehend Piktos mit lackiertem eloxiertem Profil (beidseitig). Gewölbtes-Profil Aluminium-Beschilderung. Mit Kunststoffbeschichtung versehen, welche sich gut zum Mehrfachbeleben oder Bedrucken von Texten eignen. Einfache Montage.

IT | Pittogramma bifacciale curvo

Profilo curvo da parete in alluminio anodizzato naturale. Il foglio protettivo trasparente permette di aggiungere su fogli pittogrammi o testo. Posizionare su muro con viti.

PO | Pictograma projectado em perfil curvo

Sinalética projectada em perfil curvo para pictogramas (dupla face). É fabricada com perfil em alumínio anodizado na cor prata mate. O suporte permite a colocação do papel (pictograma ou texto). Através de uma ventosa pode-se levantar o plástico que o protege.

CURVO

PS design



A



B



282



- ES - Los rótulos se suministran sin papel.
- GB - Signs supplied without paper.
- FR - Signalétique livrée sans papier.
- DE - Beschilderung ohne Papier geliefert.
- IT - Segni forniti senza carta.
- PO - Sinalética fornecida sem papel.

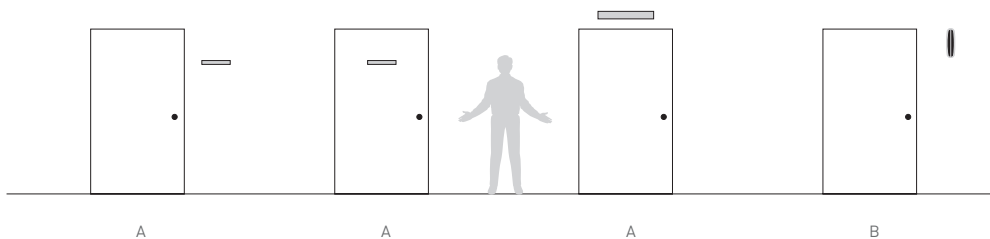

ES | Rótulo mural perfil curvo

Rótulo mural de perfil curvo. Está fabricado con perfil de aluminio anodizado en color plata mate. El soporte permite la incorporación del papel (pictograma o texto). Mediante una ventosa especial se puede levantar frontalmente el plástico transparente que lo protege.

GB | Curved profile sign

Wall curved profile sign made with silver anodised aluminium frame. The transparent sleeve allows you to add paper with pictograms or text. With a suction cup pull off the transparent sleeve to change the text. Placed on the wall with screws or with adhesive.

FR | Signalétique profil courbe

Profil mural en aluminium anodisé convexe pour signalétique ou pictogrammes. L'incorporation de l'information papier (picto ou texte) est facile. Grâce à une ventouse on enlève le plastic transparent qui protège le support et on insère le texte. Option adhesifs.

DE | Gewölbtes-Profil Reschilderung

Gewölbtes-Profil Beschilderung mit anodisiertem Alu-Profil. Mit einer Kunststoffbeschichtung versehen, die sich gut zum Mehrfachbekleben oder Bedrucken von Texten oder Pictos eignet. Einfache Montage.

IT | Segnaletica curva da muro

Profilo curvo da parete in alluminio anodizzato naturale. Il foglio protettivo trasparente (che si toglie con l'ausilio di una ventosa) permette di aggiungere su fogli pittogrammi o testo. Posizionare su muro con viti o biadesivo.

PO | Sinalética de parede em perfil curvo

Sinalética de parede em perfil curvo. É fabricada com perfil em alumínio anodizado na cor prata mate. O suporte permite a colocação do papel (pictograma ou texto). Através de uma ventosa especial pode-se levantar o plástico transparente que o protege.

A mural

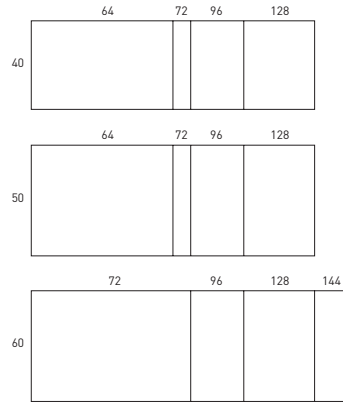
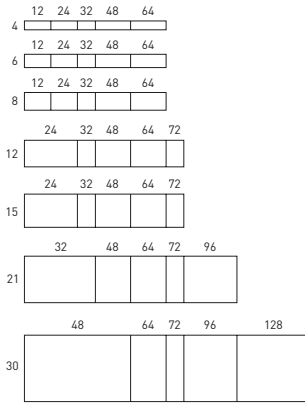

	↑	▶ ◀
799/4/12/M	4 x 12	0,8
799/4/24/M	4 x 24	0,8
799/4/32/M	4 x 32	0,8
799/4/48/M	4 x 48	0,8
799/4/64/M	4 x 64	0,8
799/6/12/M	6 x 12	0,8
799/6/24/M	6 x 24	0,8
799/6/32/M	6 x 32	0,8
799/6/48/M	6 x 48	0,8
799/6/64/M	6 x 64	0,8
799/8/12/M	8 x 12	1
799/8/24/M	8 x 24	1
799/8/32/M	8 x 32	1
799/8/48/M	8 x 48	1
799/8/64/M	8 x 64	1
799/12/24/M	12 x 24	1
799/12/32/M	12 x 32	1
799/12/48/M	12 x 48	1
799/12/64/M	12 x 64	1
799/12/72/M	12 x 72	1
799/15/24/M	15 x 24	1,2
799/15/32/M	15 x 32	1,2
799/15/48/M	15 x 48	1,2
799/15/64/M	15 x 64	1,2
799/15/72/M	15 x 72	1,2

	↑	▶ ◀
799/21/32/M	21 x 32	1,4
799/21/48/M	21 x 48	1,4
799/21/64/M	21 x 64	1,4
799/21/72/M	21 x 72	1,4
799/21/96/M	21 x 96	1,4
799/30/48/M	30 x 48	1,8
799/30/64/M	30 x 64	1,8
799/30/72/M	30 x 72	1,8
799/30/96/M	30 x 96	1,8
799/30/128/M	30 x 128	1,8
799/40/64/M	40 x 64	2
799/40/72/M	40 x 72	2
799/40/96/M	40 x 96	2
799/40/128/M	40 x 128	2
799/50/64/M	50 x 64	2,5
799/50/72/M	50 x 72	2,5
799/50/96/M	50 x 96	2,5
799/50/128/M	50 x 128	2,5
799/60/72/M	60 x 72	3
799/60/96/M	60 x 96	3
799/60/128/M	60 x 128	3
799/60/144/M	60 x 144	3

B proyec-tado

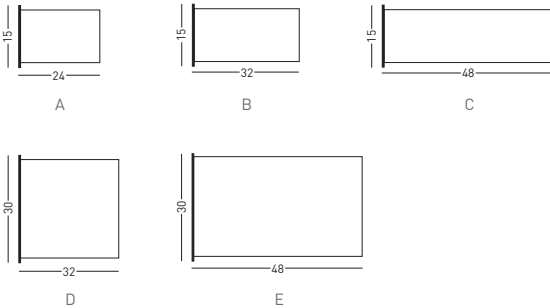

	↑	▶ ◀
A 799/15/24/P	15 x 24	2,4
B 799/15/32/P	15 x 32	2,4
C 799/15/48/P	15 x 48	2,4
D 799/30/32/P	30 x 32	3,6
E 799/30/48/P	30 x 48	3,6



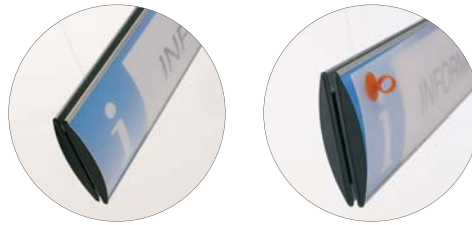

284

- ES - Los rótulos se suministran sin papel.
 GB - Signs supplied without paper.
 FR - Signalétique livrée sans papier.
 DE - Beschilderung ohne Papier geliefert.
 IT - Segni forniti senza carta.
 PO - Sinalética fornecida sem papel.



	↖	↗
799/8/48/S	8 x 48	2
799/8/64/S	8 x 64	2
799/8/96/S	8 x 96	2
799/12/48/S	12 x 48	2
799/12/64/S	12 x 64	2
799/12/96/S	12 x 96	2
799/15/48/S	15 x 48	2,4
799/15/64/S	15 x 64	2,4
799/15/96/S	15 x 96	2,4

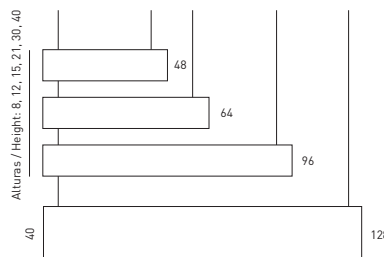

	↖	↗
799/21/48/S	21 x 48	2,8
799/21/64/S	21 x 64	2,8
799/21/96/S	21 x 96	2,8
799/30/48/S	30 x 48	3,6
799/30/64/S	30 x 64	3,6
799/30/96/S	30 x 96	3,6
799/40/64/S	40 x 64	4
799/40/96/S	40 x 96	4
799/40/128/S	40 x 128	4

ES | Rótulo suspendido perfil curvo
 Rótulo suspendido doble cara de perfil curvo. Está fabricado con perfil de aluminio anodizado en color plata mate. El soporte permite la incorporación del papel (pictograma o texto). Mediante una ventosa especial se puede levantar el plástico protector.

GB | Suspended curved profile signs
 Wall curved profile double side signs made with silver anodised aluminium frame. The transparent sleeve allows you to add paper with pictograms or text. With a suction cup pull off the transparent sleeve to change the text.

FR | Signalétique suspendu profil courbe
 Profil suspendu double face en aluminium anodisé convexe pour signalétique ou pictogrammes. L'incorporation de l'information papier (picto ou texte) est facile. Grâce à une ventouse on enlève le plastic transparent qui protège le support et on insère le texte.

DE | Gewölbtes-profil beschilderung
 Gewölbtes-Profil Beschilderung mit anodisiertem Alu-Profil. Mit einer Kunststoffbeschichtung versehen, die sich gut zum Mehrfachbeleben oder Bedrucken von Texten oder Pictos eignet. Einfache Montage. Deckenhalter mit Nylonzwirn (linkl).

IT | Segnaletica bifacciale curva sospesa
 Profilo curvo sospesa in alluminio anodizzato naturale. Il foglio protettivo trasparente (che si toglie con l'ausilio di una ventosa) permette di aggiungere su fogli pittogrammi o testo. Le informazioni possono essere visualizzate su più linee e su entrambi i lati.

PO | Sinalética suspensa em perfil curvo
 Sinalética suspensa dupla face em perfil curvo. É fabricada com perfil em alumínio anodizado na cor prata mate. O suporte permite a colocação do papel (pictograma ou texto). Através de uma ventosa especial pode-se levantar o plástico transparente que o protege.



CURVO
PS design

06
Rotulplan
Planning Sisplano

285

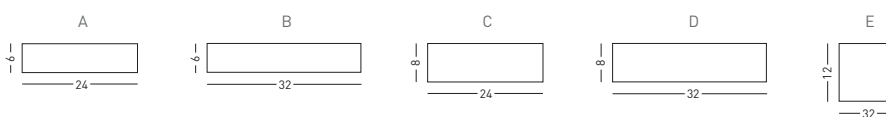

A	799/6/24/SB	6 x 24	0,8
B	799/6/32/SB	6 x 32	0,8
C	799/8/24/SB	8 x 24	1
D	799/8/32/SB	8 x 32	1
E	799/12/12/SB	12 x 12	1

ES | Rótulo sobremesa perfil curvo

Rótulo de sobremesa perfil curvo. Está fabricado con perfil de aluminio anodizado en color plata mate. El soporte permite la incorporación del papel (pictograma o texto) Mediante una ventosa especial se puede levantar el plástico protector.

FR | Signalétique à poser profil courbe

Signalétique à poser, en aluminium anodisé convexe pour signalétique ou pictogrammes. L'incorporation de l'information papier (picto ou texte) est facile. Grâce à une ventouse on enlève le plastic transparent qui protège le support et on insère le texte.

IT | Segnaletica curva da tavolo

Profilo curvo da tavolo in alluminio anodizzato naturale. Il foglio protettivo trasparente (che si toglie con l'ausilio di una ventosa) permette di aggiungere su fogli pittogrammi o testo.

GB | Desk curved profile signs

Signs with curved profile desks wall are made with silver anodised aluminium frame. The transparent sleeve allows you to add paper with pictograms or text. With a suction cup pull off the transparent sleeve to change the text.

DE | Gewölbtes-profil Tischaufsteller

Gewölbtes-Profil Tischaufsteller mit anodisiertem Alu-Profil, silber eloxiert. Mit einer Kunststoffbeschichtung versehen, die sich gut zum Mehrfachbekleben oder Bedrucken von Texten oder Pictos eignet. Einfache Montage.

PO | Sinalética de mesa em perfil curvo

Sinalética de mesa em perfil curvo. É fabricada com perfil em alumínio anodizado na cor prata mate. O suporte permite a colocação do papel (pictograma ou texto). Através de uma ventosa especial pode-se levantar o plástico transparente que o protege.



- ES - Los rótulos se suministran sin papel.
 GB - Signs supplied without paper.
 FR - Signalétique livrée sans papier.
 DE - Beschilderung ohne Papier geliefert.
 IT - Segni forniti senza carta.
 PO - Sinalética fornecida sem papel.

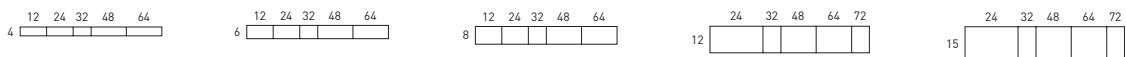

	↑	→	↖
799/4/12/M	4 x 12	0,8	
799/4/24/M	4 x 24	0,8	
799/4/32/M	4 x 32	0,8	
799/4/48/M	4 x 48	0,8	
799/4/64/M	4 x 64	0,8	
799/6/12/M	6 x 12	0,8	
799/6/24/M	6 x 24	0,8	
799/6/32/M	6 x 32	0,8	
799/6/48/M	6 x 48	0,8	
799/6/64/M	6 x 64	0,8	

	↑	→	↖
799/8/12/M	8 x 12	1	
799/8/24/M	8 x 24	1	
799/8/32/M	8 x 32	1	
799/8/48/M	8 x 48	1	
799/8/64/M	8 x 64	1	
799/12/24/M	12 x 24	1	
799/12/32/M	12 x 32	1	
799/12/48/M	12 x 48	1	
799/12/64/M	12 x 64	1	
799/12/72/M	12 x 72	1	

	↑	→	↖
799/15/24/M	15 x 24	1,2	
799/15/32/M	15 x 32	1,2	
799/15/48/M	15 x 48	1,2	
799/15/64/M	15 x 64	1,2	
799/15/72/M	15 x 72	1,2	

ES | Directorios perfil curvo

Rótulo mural de perfil curvo. Está fabricado con perfil de aluminio anodizado en color plata mate. El soporte permite la incorporación del papel (pictograma o texto). Mediante una ventosa especial se puede levantar frontalmente el plástico transparente que lo protege.

GB | Curved profile directories

Wall curved profile sign made with silver anodised aluminium frame. The transparent sleeve allows you to add paper with pictograms or text. With a suction cup pull off the transparent sleeve to change the text. Placed on the wall with screws or with adhesive.

FR | Multi-plaques profil courbe

Profil mural en aluminium anodisé convexe pour signalétique ou pictogrammes. L'incorporation de l'information papier (picto ou texte) est facile. Grâce à une ventouse on enlève le plastic transparent qui protège le support et on insère le texte.

DE | Wegweisersystem Gewölbtes-Profil

Gewölbtes-Profil Beschilderung mit anodisiertem Alu-Profil. Mit einer Kunststoffbeschichtung versehen, die sich gut zum Mehrfachbeleben oder Bedrucken von Texten oder Pictos eignet. Einfache Montage.

IT | Segnaletica curva direzionale da muro

Profilo curvo da parete in alluminio anodizzato naturale. Il foglio protettivo trasparente (che si toglie con l'ausilio di una ventosa) permette di aggiungere su fogli pittogrammi o testo. Posizionare su muro con viti o biadesivo.

PO | Directório de parede em perfil curvo

Sinalética de parede em perfil curvo. É fabricada com perfil em alumínio anodizado na cor prata mate. O suporte permite a colocação do papel (pictograma ou texto). Através de uma ventosa especial pode-se levantar o plástico transparente que o protege.



CURVO

PS design

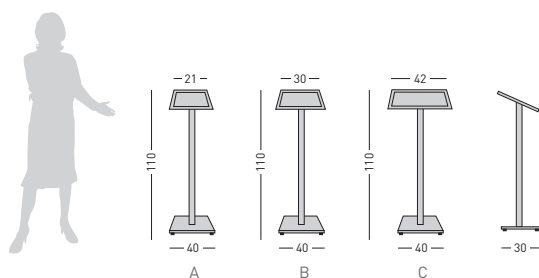

A	794/21/AT	110	21 x 21
B	794/A4/AT	110	21 x 30
C	794/A3/AT	110	30 x 42

ES | Atril con perfil curvo

Atril de aluminio y base metálica con rótulo curvo de aluminio provisto de plástico protector antireflex. Disponible en medidas 21 x 21 cm., Din A4 y Din A3.

FR | Chevalet avec signalétique courbe

Chevalet en aluminium et base métallique avec signalétique courbe en aluminium pourvu d'un plastique protecteur anti reflets/anti UV. Dimensions 21 x 21 cm, A4 ou A3.

IT | Leggio con etichetta profilo ricurvo

Leggio in alluminio e base metallica con segnaletica curva in alluminio provvisto di plastica protettrice antiriflesso. Disponibile nelle misure 21 x 21 cm, Din A4 e Din A3.

GB | Lectern with curved sign

Lectern in aluminium and metallic base with aluminium curved sign with a plastic protection antireflex/UV-stabilized. Dimensions 21 x 21 cm, A4 or A3.

DE | Stehpult aus Aluminiumbasis

Stehpult aus Aluminiumbasis mit gebogenem Plasticschild. Erhältlich in 21 x 21 cm, DIN A4 und DIN A3.

PO | Expositor com sinalética em perfil curvo

Expositor em alumínio e base metálica, com sinalética curva em alumínio com um plástico protector anti-reflexo. Disponível nas medidas 21 x 21, DIN A4 e DIN A3.

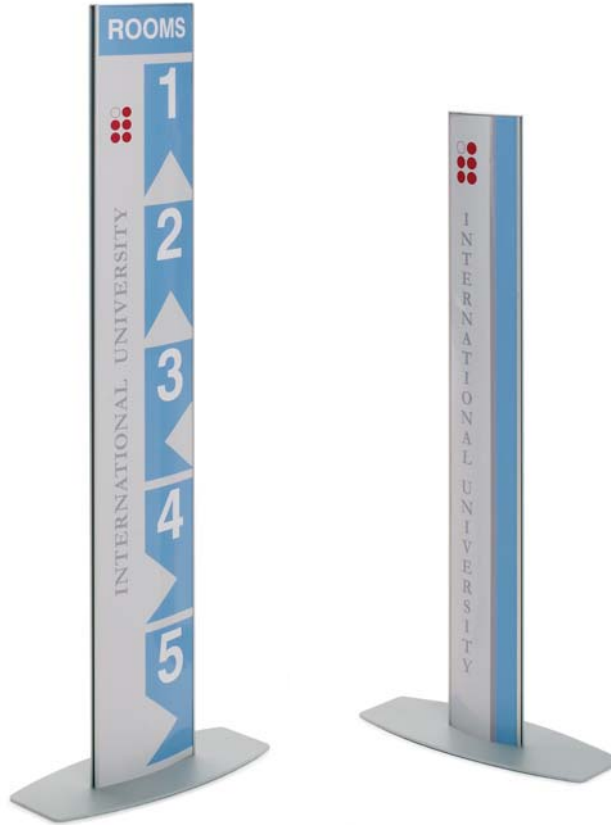

- ES - Los rótulos se suministran sin papel.
- GB - Signs supplied without paper.
- FR - Signalétique livrée sans papier.
- DE - Beschilderung ohne Papier geliefert.
- IT - Segni forniti senza carta.
- PO - Sinalética fornecida sem papel.

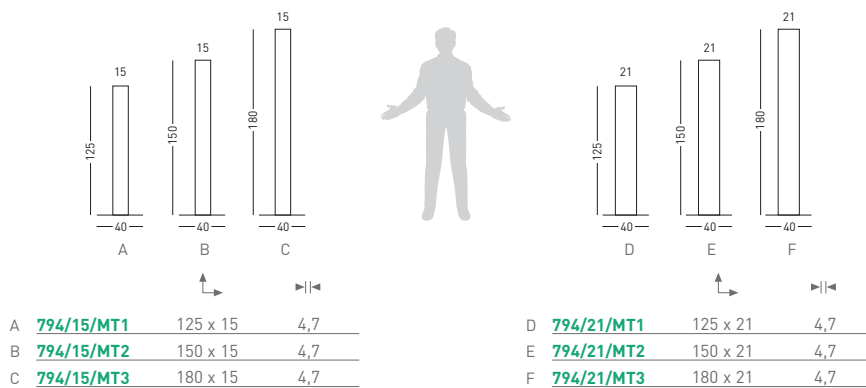

ES | Mini totems perfil curvo

Mini Totem de aluminio fabricados con perfil curvo provistos de base metálica para ubicar en áreas de interior, de medidas 15 y 21 cm. Permiten personalizarse con una impresión que se ubica debajo del plástico protector transparente antireflex.

FR | Mini Totem en aluminium courbe

Mini Totem en aluminium courbe, pour l'intérieur. Le support permet d'insérer une feuille de papier (pictogramme ou texte) après avoir enlevé la protection en plastique (anti UV/anti reflets) grâce à une ventouse.

IT | Mini totem in alluminio ricurvo

Mini Totem per interni in alluminio fabbricato con profilo curvo, misure 15 e 21 cm. E' possibile personalizzarlo tramite impressione situata al di sotto della plastica trasparente protettiva antiriflesso.

GB | Mini Totem in curved aluminium

Mini Totem in curved aluminium for the inside. The support allows to insert a sheet of paper after having removed the plastic protection (UV stabilized/antireflex) thanks to a suction pad.

DE | Gewölbtes mini Totem aus Aluminium

Gewölbtes mini Totem aus Aluminium, zur Wegeleitung im Innenbereich, in den Größen 15 und 21 cm. Es ermöglicht die eigene Gestaltung, dadurch das diese unter einer durchsichtigen, antireflex Plastik-Schutzfolie.

PO | Mini Totem em perfil curvo

Mini Totem em alumínio, fabricado com perfil curvo. Apto para ser colocado em áreas interiores, disponível nas medidas de 15 e 21 cm. Permite ser personalizado com uma impressão que se coloca por baixo do plástico protector transparente anti-reflexo.



CURVO

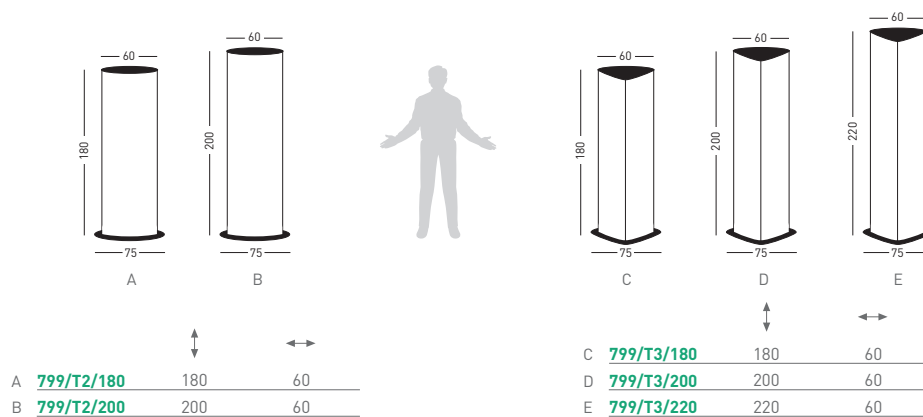

ES | Totems perfil curvo

Totems verticales doble o triple cara de perfil curvo. Están fabricados con perfil de aluminio anodizado en color plata mate. El soporte permite la incorporación del documento mediante una ventosa especial para levantar el plástico transparente que lo protege.

FR | Totem profil courbe

Totems sur profil courbe en aluminium anodisé double et triple face. Le support permet l'incorporation de papier (pictos ou texte) grâce à une ventouse on enlève le plastique transparent qui protège le support et ainsi changer l'information.

IT | Totem profilo curvo

Totems verticali doppio o triplo lato profilo curvo. Realizzato in alluminio anodizzato argento opaco. La staffa consente l'incorporazione del documento attraverso una ventosa speciale per sollevare la plastica trasparente che lo protegge.

GB | Curved profile totem

Totem double or triple side made of anodized aluminium, which allow to switch texts and pictograms with a suction cup to pull off the transparent sleeve to change the information.

DE | Gewölbtes-Profil Totem

Gewölbtes-Profil Totem beidseitig und dreiseitig mit anodisiertem Alu-Profil hergestellt. Mit einer Kunststoffbeschichtung versehen, die sich gut zum Mehrfachbekleben oder Bedrucken von Texten oder Pictos eignet.

PO | Totem em perfil curvo

Totems verticais dupla e tripla face em perfil curvo. Fabricados com perfil em alumínio anodizado na cor prata mate. O suporte permite a colocação do documentos através de uma ventosa especial para levantar o plástico transparente que o protege.



290

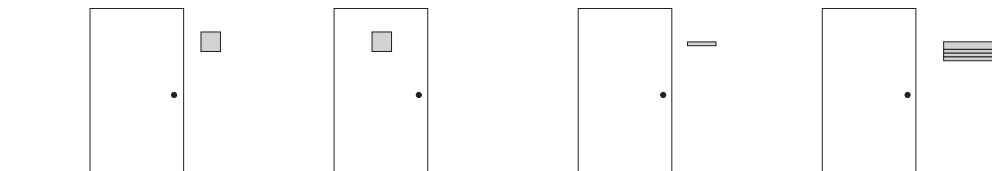

ES | Rótulo mural perfil curvo "Braille"

Rótulo en alto relieve y braille de sobremesa perfil curvo. Está fabricado con perfil de aluminio anodizado en color plata mate. El soporte permite la incorporación del papel (pictograma o texto).

FR | Pictogramme mural courbe "Braille"

Pictogramme mural sur profil courbe en haut relief et braille. Fabriqué en aluminium anodisé mat. Les fixations latérales sont métalliques et peintes en noir. Livré avec visserie, (adhésif double-face à préciser à la commande).

IT | Etichetta pittogramma curva "Braille"

Segnaletica da parete profilo curvo arrotondato in alto rilievo e braille per pittogramma murale. Fabricato con profilo in alluminio anodizzato colore argento opaco e tappi laterali metallici dipinti di nero.

GB | Wall curved profile pictogram "Braille"

Wall pictogram on curved profile, in high-relief and braille. Mat anodized aluminium. Black metallic side fixations. Delivered with screws set (adhesive tape to precise when ordering).

DE | Gewölbtes Wand-Profil "Braille"

Gewölbtes Wand-Profil "Braille". Beschilderung in Hochrelief und gewölbtes Porfil. Aus anodisiertem Aluminium silber matt eloxiert. Eine Beschichtung eignet sich fürs Piktogramm oder Text.

PO | Pictograma curvo de parede "Braille"

Sinalética de parede em perfil curvo com alto relevo e Braille. Fabricado com perfil em alumínio anodizado na cor prata mate e tampas laterais metálicas pintadas em preto.

A picto

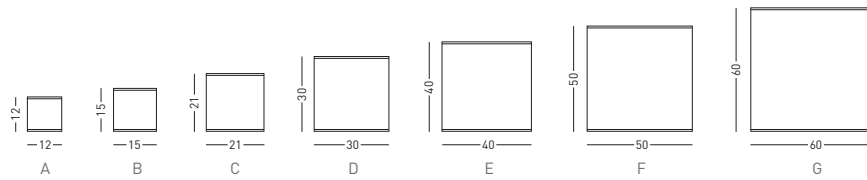

A	793/M/12/BLL	12 x 12	1	☑	F	793/M/50/BLL	50 x 50	2,5	☑
B	793/M/15/BLL	15 x 15	1,2	☑	G	793/M/60/BLL	60 x 60	3	☑
C	793/M/21/BLL	21 x 21	1,4	☑		793/M/A5/BLL	21 x 15	1,2	A5
D	793/M/30/BLL	30 x 30	1,8	☑		793/M/A4/BLL	29,7 x 21	1,4	A4
E	793/M/40/BLL	40 x 40	2	☑		793/M/A3/BLL	42 x 29,7	1,8	A3



B rótulo

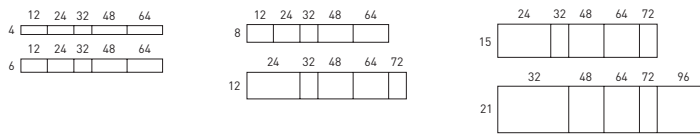

799/4/12/M/BLL	4 x 12	0,8	799/8/12/M/BLL	8 x 12	1	799/15/24/M/BLL	15 x 24	1,2
799/4/24/M/BLL	4 x 24	0,8	799/8/24/M/BLL	8 x 24	1	799/15/32/M/BLL	15 x 32	1,2
799/4/32/M/BLL	4 x 32	0,8	799/8/32/M/BLL	8 x 32	1	799/15/48/M/BLL	15 x 48	1,2
799/4/48/M/BLL	4 x 48	0,8	799/8/48/M/BLL	8 x 48	1	799/15/64/M/BLL	15 x 64	1,2
799/4/64/M/BLL	4 x 64	0,8	799/8/64/M/BLL	8 x 64	1	799/15/72/M/BLL	15 x 72	1,2
799/6/12/M/BLL	6 x 12	0,8	799/12/24/M/BLL	12 x 24	1	799/21/32/M/BLL	21 x 32	1,4
799/6/24/M/BLL	6 x 24	0,8	799/12/32/M/BLL	12 x 32	1	799/21/48/M/BLL	21 x 48	1,4
799/6/32/M/BLL	6 x 32	0,8	799/12/48/M/BLL	12 x 48	1	799/21/64/M/BLL	21 x 64	1,4
799/6/48/M/BLL	6 x 48	0,8	799/12/64/M/BLL	12 x 64	1	799/21/72/M/BLL	21 x 72	1,4
799/6/64/M/BLL	6 x 64	0,8	799/12/72/M/BLL	12 x 72	1	799/21/96/M/BLL	21 x 96	1,4



- | | | | | | |
|----------------------------------|---------------------------------|--------------------------------|--------------------------------------|------------------------------------|------------------------------------|
| 1 Aseos caballero
Men toilets | 8 Guardarropa
Cloakroom | 16 Subida esc.
Up stairs | 36 Ducha
Shower | 45 Recepción
Reception | 54 Esc. Mecán.
Escalator |
| 2 Aseos señora
Women toilets | 9 No pasar
Do not cross | 18 Bajada esc.
Down stairs | 37 Piscina
Swimming pool | 47 Sala TV.
TV room | 60 Fumadores
Smoking room |
| 3 Aseos
Toilets/restroom | 10 No fumar
No smoking | 20 Sala espera
Waiting room | 39 Vest. Masculino
Men Chan. room | 48 Serv. Médicos
Medical facil. | 61 Animales no
No anim. entry |
| 4 Restaurante
Restaurant | 11 Flecha
Arrow | 21 Salida
Way out | 40 Vest. Femenino
Wom. Chan. room | 49 Hospital
Hospital | 64 Enfermería
Infirmary |
| 5 Cafeteria
Coffee shop | 13 Ascensor
Lift | 22 Entrada
Way in | 41 Peluquería
Hairdresser | 50 Silencio
Silence | 69 Basuras no
Rubbish bin |
| 6 Teléfono
Telephone | 14 Minusválido
Disable | 24 Limpieza
Cleaning room | 42 Oficina
Office | 51 Punto de enc.
Meeting point | 74 Fotos no
No cameras |
| 7 Información
Information | 15 S. Reuniones
Meeting room | 25 Correos
Post office | 44 Consigna
Lockers | 52 Biblioteca
Library | 164 Móviles no
No mobile phones |

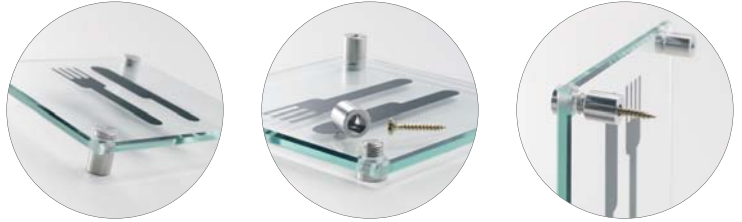

292

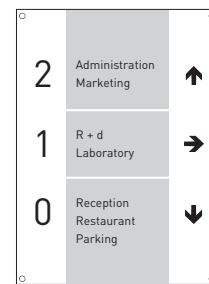
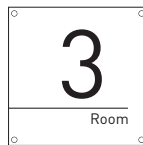

ES | Pictograma de vidrio

Pictograma fabricado en vidrio templado y silueta termogravada mediante sistema de calca. La gama 796 se fija a la pared atornillando los separadores de acero inoxidable (opcionalmente con kit 796/KAR adhesivos).

GB | Glass picto

Pictos made of tempered glass and tracing paper silhouette through thermograving. The range 796 is fixed to the wall through stainless steel screws (optionally with kit 796/KAR adhesives).

FR | Picto en verre

Gammes de pictogrammes en verre. Silhouette thermo gravée avec un système de calque. Formats pour tous les usages: signalétique directionnelle, accueil, etc. La gamme 796 est livrée avec la visserie, fixation rapide avec entretoises en acier inox. Option adhesifs.

DE | Glasklare Picto

Pictogramme aus gehärtetem Glas und Halter aus rostfreiem Edelstahl. Silhouette mit Thermogravierung mittels Durchschlag/Kopie. Die Palette 796 wird an die Wand durch Schrauben befestigt (nach Wahl mit kit 796/KAR Doppelte Selbstklebebande).

IT | Pittogramma in vetro

Pittogramma fatto di vetro temperato e stampa in prespaziato. La gamma 796 è fissata al muro tramite viti in acciaio (opzionalmente col il kit 796/KAR adesivo). La referenza 796/0 può essere consegnata con pittogrammi in vinile della Rotul Plan se ordinata.

PO | Pictograma em vidro

Pictograma fabricado em vidro temperado e silhueta termo-gravada através do sistema de decalagem. A gama 796 é fixada à parede aparafusando os separadores de aço inoxidável (opcionalmente com o kit 796/KAR de adesivos).

A pictos

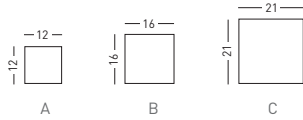

A	796/M/12	12 x 12	0,9
B	796/M/16	16 x 16	0,9
C	796/M/21	21 x 21	0,9

* **796/KAR** Ø 1
 - Kit de adhesivos (4 uds)
 - Adhesive kit (4 uts)

796/K4 Ø 1
 - Kit de separadores (4 uds)
 - Separator kit (4 uts)



B directorios

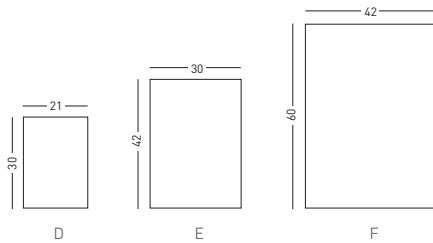

D	796/M/A4	30 x 21	0,9
E	796/M/A3	42 x 30	0,9
F	796/M/A2	60 x 42	0,9



* Indicar color del vinilo
 * Indicate vinyl color



- 1 Aseos caballero
Men toilets
- 2 Aseos señora
Women toilets
- 3 Aseos
Toilets/restroom
- 4 Restaurante
Restaurant
- 5 Cafeteria
Coffee shop
- 6 Teléfono
Telephone
- 7 Información
Information Bint

- 8 Guardarropa
Cloakroom
- 9 No pasar
Do not cross
- 10 No fumar
No smoking
- 11 Flecha
Arrow
- 13 Ascensor
Lift
- 14 Minusválido
Disable
- 15 S. Reuniones
Meeting room

- 16 Subida esc.
Up stairs
- 18 Bajada esc.
Down stairs
- 20 Sala espera
Waiting room
- 21 Salida
Way out
- 22 Entrada
Way in
- 24 Limpieza
Cleaning room
- 25 Correos
Post office

- 36 Ducha
Shower
- 37 Piscina
Swimming pool
- 39 Vest. Masculino
Men Chan. room
- 40 Vest. Femenino
Wom. Chan. room
- 41 Peluquería
Hairdresser
- 42 Oficina
Office
- 44 Consigna
Lockers

- 45 Recepción
Reception
- 47 Sala TV.
TV room
- 48 Serv. Médicos
Medical facil.
- 49 Hospital
Hospital
- 50 Silencio
Silence
- 51 Punto de enc.
Meeting point
- 52 Biblioteca
Library

- 54 Esc. Mecán.
Escalator
- 60 Fumadores
Smoking room
- 61 Animales no
No anim. entry
- 64 Enfermería
Infirmary
- 69 Basuras no
Rubbish bin
- 74 Fotos no
No cameras
- 164 Móviles no
No mobile phones



A

294

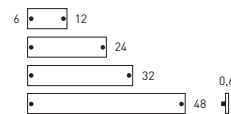
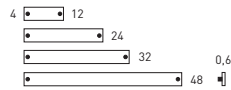

	↑	→	
798/4/12/M	4 x 12	0,6	
798/4/24/M	4 x 24	0,6	
798/4/32/M	4 x 32	0,6	
798/4/48/M	4 x 48	0,6	
A 796/KAR	Ø 1	-	

	↑	→	
798/6/12/M	6 x 12	0,6	
798/6/24/M	6 x 24	0,6	
798/6/32/M	6 x 32	0,6	
798/6/48/M	6 x 48	0,6	

ES | Rótulo de vidrio

Rótulo fabricado en vidrio templado transparente rotulado mediante vinilo negro. Se fija a la pared atornillando los separadores de acero inoxidable o con kit 796/KAR adhesivos.

FR | Signalétique en verre

Signalétique en verre transparent pour tout types de présentation. Livrée avec la visserie, fixation rapide avec entretoises en acier inox, optionnel avec kit 796/KAR adhésives. On peut ajouter pictogrammes et flèches d'orientation.

IT | Segnaletica in vetro

Segnaletica in vetro temperato e vinile nero. Fissata a muro con viti in acciaio inox o il kit 796/KAR adesivo. Si possono aggiungere pittogrammi o frecce.

GB | Glass sign

Signs made transparent tempered glass and black vinyl. They are fixed to the wall through stainless steel screws or with kit 796/KAR adhesives. You can add pictograms and arrows to chosen text.

DE | Kristallklare Beschilderungssystem

Beschilderung aus gehärtetem Glas Halter aus rostfreiem Edelstahl. Der Text ist in schwarzem Vinyl beschriftet. Befestigung an der Wand durch Schraube oder mit dem Kit 796/KAR Klebeband.

PO | Sinalética em vidro

Sinalética fabricada em vidro temperado transparente com vinilado na cor preta. Fixa-se à parede aparafusando os separadores de aço inoxidável ou com o kit 796/KAR de adesivos.



VIDRIO

PS design

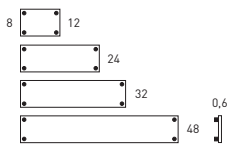

798/8/12/M	8 x 12	0,6
798/8/24/M	8 x 24	0,6
798/8/32/M	8 x 32	0,6
798/8/48/M	8 x 48	0,6

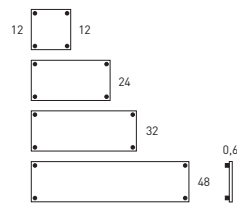

798/12/12/M	12 x 12	0,6
798/12/24/M	12 x 24	0,6
798/12/32/M	12 x 32	0,6
798/12/48/M	12 x 48	0,6

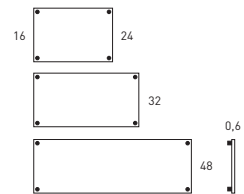

798/16/24/M	16 x 24	0,6
798/16/32/M	16 x 32	0,6
798/16/48/M	16 x 48	0,6
A 796/KAR	Ø 1	-

ES | Rótulos de vidrio

Rótulo fabricado en vidrio templado transparente rotulado mediante vinilo negro. Se fija a la pared atornillando los separadores de acero inoxidable o con kit 796/KAR adhesivos.

GB | Glass sign

Signs made transparent tempered glass and black vinyl. They are fixed to the wall through stainless steel screws or with kit 796/KAR adhesives. You can add pictograms and arrows to chosen text.

FR | Signalétique en verre

Signalétique en verre transparent pour tout types de présentation. Livrée avec la visserie, fixation rapide avec entretoises en acier inox, optionnel avec kit 796/KAR adhésives. On peut ajouter pictogrammes et flèches d'orientation.

DE | Kristallklare Beschilderungssystem

Beschilderung aus gehärtetem Halter aus rostfreiem Edelstahl. Der Text ist in schwarzem Vinyl beschriftet. Befestigung an der Wand durch Schraube oder mit dem Kit 796/KAR Klebeband.

IT | Segnaletica in vetro

Segnaletica in vetro temperato e vinile nero. Fissata a muro con viti in acciaio inox o il kit 796/KAR adesivo. Si possono aggiungere pittogrammi o frecce.

PO | Sinalética em vidro

Sinalética fabricada em vidro temperado transparente vinilado na cor preta. Fixa-se á parede aparafusando os separadores de aço inoxidável ou com o kit 796/KAR de adesivos.

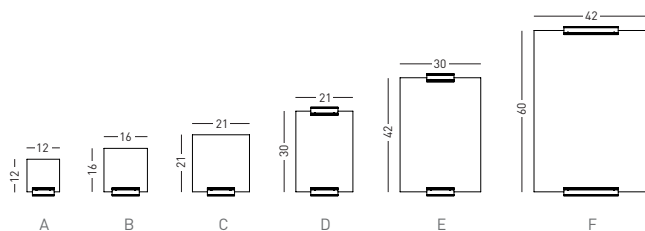
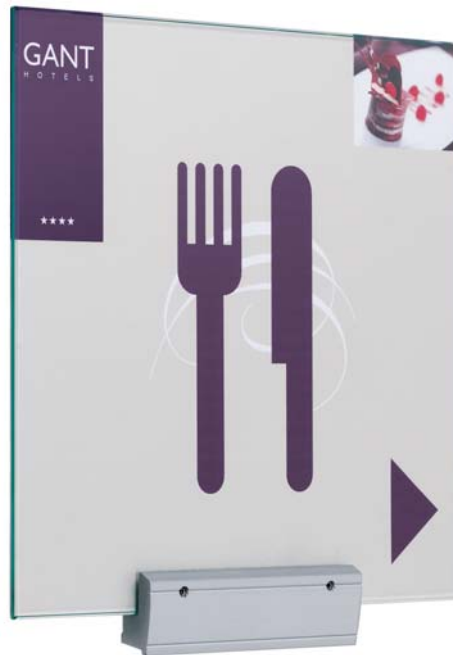

		↑	↔
A	GR/12/M	12 x 12	1,6
B	GR/16/M	16 x 16	1,6
C	GR/21/M	21 x 21	1,6
D	GR/A4/M	30 x 21	1,6
E	GR/A3/M	42 x 30	1,6
F	GR/A2/M	60 x 42	1,6

ES | Pictogramas y directorios "Grip"

Sistema de señalización de interiores fabricado en aluminio y vidrio. La pinza "Grip" de aluminio disponible en diversos formatos sujeta el rótulo situado entre el cristal y la trasera metálica. Disponible en versión mural, sobremesa y con soporte.

GB | Wall sign "Grip"

Signing system for the inside in anodized aluminium and glass. The grip is available in various sizes. Wall, table or stand version. Delivered with one allen key. Picto and text not included.

FR | Signalétique murale "Grip"

Système de signalisation d'intérieur en aluminium anodisé et verre. La pince est disponible en divers formats, version murale, sur table ou avec piétement. Livré avec une clé allen. Picto et texte non inclus.

DE | Rettungszeichen "Grip"

Rettungszeichen für den Innenbereich aus Aluminium oder Glas. Die Pinzette "Grip" ist in verschiedenen Formaten erhältlich. Erhältlich für Wand, Tisch oder mit Standbein. Keine Textverarbeitung möglich.

IT | Etichetta da parete "Grip"

Sistema di segnaletica da interni fabbricato in alluminio e vetro. La pinza "Grip" è disponibile in diversi formati. Disponibile nella versioni da parete, da tavolo e con supporto. Include la chiave Allen corrispondente. Non include la realizzazione del testo.

PO | Sinalética de parede "Grip"

Sistema de sinalética para interior, fabricado em alumínio e vidro. A pinça "Grip" está disponível em diversos formatos. Disponível na versão de parede, de mesa e com suporte. Inclui chave para montagem. Não inclui a produção dos textos.



*

GRIP
PS design

06
Rotulplan
Planning Sisplano

297

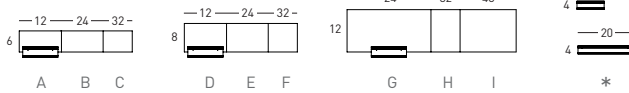

	↑	→	
A	GR/6/12/M	6 x 12	1,6
B	GR/6/24/M	6 x 24	1,6
C	GR/6/32/M	6 x 32	1,6
D	GR/8/12/M	8 x 12	1,6
E	GR/8/24/M	8 x 24	1,6
F	GR/8/32/M	8 x 32	1,6
G	GR/12/24/M	12 x 24	1,6
H	GR/12/32/M	12 x 32	1,6
I	GR/12/48/M	12 x 48	1,6
* ↑ →			
	GR/10	4 x 10	1,6
	GR/20	4 x 20	1,6

ES | Pictogramas y directorios "Grip"

Sistema de señalización de interiores fabricado en aluminio y vidrio. La pinza "Grip" de aluminio disponible en diversos formatos sujeta el rótulo situado entre el cristal y la trasera metálica. Disponible en versión mural, sobremesa y con soporte.

GB | Wall sign "Grip"

Signing system for the inside in anodized aluminium and glass. The grip is available in various sizes. Wall, table or stand version. Delivered with one allen key. Picto and text not included.

FR | Signalétique murale "Grip"

Système de signalisation d'intérieur en aluminium anodisé et verre. La pince est disponible en divers formats, version murale, sur table ou avec piétement. Livré avec une clé allen. Picto et texte non inclus.

DE | Rettungszeichen "Grip"

Rettungszeichen für den Innenbereich aus Aluminium oder Glas. Die Pinzette "Grip" ist in verschiedenen Formaten erhältlich. Erhältlich für Wand, Tisch oder mit Standbein. Keine Textverarbeitung möglich.

IT | Etichetta da parete "Grip"

Sistema di segnaletica da interni fabbricato in alluminio e vetro. La pinza "Grip" è disponibile in diversi formati. Disponibile nella versioni da parete, da tavolo e con supporto. Include la chiave Allen corrispondente. Non include la realizzazione del testo.

PO | Sinalética de parede "Grip"

Sistema de sinalética para interior, fabricado em alumínio e vidro. A pinça "Grip" está disponível em diversos formatos. Disponível na versão de parede, de mesa e com suporte. Inclui chave para montagem. Não inclui a produção dos textos.

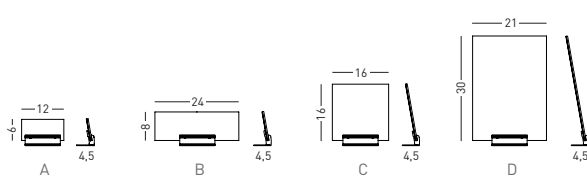

A	GR/6/12/SB	6 x 12	4,5
B	GR/8/24/SB	8 x 24	4,5
C	GR/16/SB	16 x 16	4,5
D	GR/A4/SB	30 x 21	4,5

ES | Rótulos de sobremesa "Grip"

Sistema de señalización de interiores fabricado en aluminio y vidrio. La pinza "Grip" de aluminio disponible en diversos formatos sujeta el rótulo situado entre el cristal y la trasera metálica. Disponible en versión mural, sobremesa y con soporte.

GB | Sign for table "Grip"

Signing system for the inside in anodized aluminium and glass. The grip is available in various sizes. Wall, table or stand version. Delivered with one allen key. Picto and text not included.

FR | Signalétique sur table "Grip"

Système de signalisation d'intérieur en aluminium anodisé et verre. La pince est disponible en divers formats, version murale, sur table ou avec piétement. Livré avec une clé allen. Picto et texte non inclus.

DE | Rettungszeichen "Grip"

Rettungszeichen für den Innenbereich aus Aluminium oder Glas. Die Pinzette "Grip" ist in verschiedenen Formaten erhältlich. Erhältlich für Wand, Tisch oder mit Standbein. Keine Textverarbeitung möglich.

IT | Etichetta da tavolo "Grip"

Sistema di segnaletica da interni fabbricato in alluminio e vetro. La pinza "Grip" è disponibile in diversi formati. Disponibile nella versioni da parete, da tavolo e con supporto. Include la chiave Allen corrispondente. Non include la realizzazione del testo.

PO | Sinalética de mesa "Grip"

Sistema de sinalética para interior, fabricado em alumínio e vidro. A pinça "Grip" está disponível em diversos formatos. Disponível na versão de parede, de mesa e com suporte. Inclui chave para montagem. Não inclui a produção dos textos.



GRIP
PS design

06
Rotulplan
Planning Sisplano



299

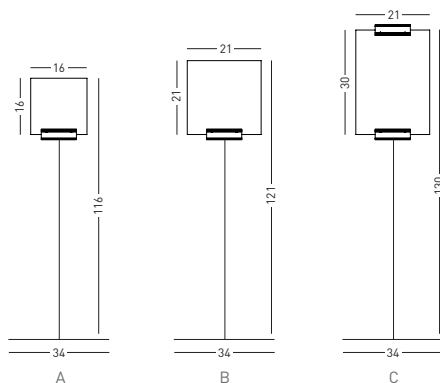

	↙	↕
A	GR/16/P	16 x 16 / 116
B	GR/21/P	21 x 21 / 121
C	GR/A4/P	30 x 21 / 130

ES | Rótulos "Grip" con soporte

Sistema de señalización de interiores fabricado en aluminio y vidrio. La pinza "Grip" de aluminio disponible en diversos formatos sujeta el rótulo situado entre el cristal y la trasera metálica. Disponible en versión mural, sobremesa y con soporte.

FR | Signalétique "Grip" sur piétement

Système de signalisation d'intérieur en aluminium anodisé et verre. La pince est disponible en divers formats, version murale, sur table ou avec piétement. Livré avec une clé allen. Picto et texte non inclus.

IT | Etichetta "Grip" con supporto

Sistema di segnaletica da interni fabbricato in alluminio e vetro. La pinza "Grip" è disponibile in diversi formati. Disponibile nella versioni da parete, da tavolo e con supporto. Include la chiave Allen corrispondente. Non include la realizzazione del testo.

GB | Sign for table "Grip"

Signing system for the inside in anodized aluminium and glass. The grip is available in various sizes. Wall, table or stand version. Delivered with one allen key. Picto and text not included.

DE | Rettungszeichen "Grip"

Rettungszeichen für den Innenbereich aus Aluminium oder Glas. Die Pinzette "Grip" ist in verschiedenen Formaten erhältlich. Erhältlich für Wand, Tisch oder mit Standbein. Keine Textverarbeitung möglich.

PO | Sinalética "Grip" com suporte

Sistema de sinalética para interior, fabricado em alumínio e vidro. A pinça "Grip" está disponível em diversos formatos. Disponível na versão de parede, de mesa e com suporte. Inclui chave para montagem. Não inclui a produção dos textos.



300



OFFICE

306

SHOWROOM

WC →

SALA 3

EXIT →

ES | Pictogramas "Typo" inox adhesivos
Pictogramas, letras y números adhesivos fabricados en acero inoxidable de 0,25 cm. Gracias a su fácil colocación permiten señalar cualquier entorno formando palabras y/o unir varios números o pictogramas. Aplicar sobre una superficie lisa.

FR | Pictogramme "Typo" inox adhésif
Pictogrammes, lettres et numéros en acier inoxydable de 0,25 cm "Typo". Installation simple et rapide sur une surface lisse grâce à un adhésif double face. Pour intérieur et semi-extérieur, peuvent être combinés pour former des mots ou suites de chiffres.

IT | Pittogramma "Typo" inox adesivo
Pittogrammi, lettere e numeri adesivi fabbricati in acciaio inossidabile di 0,25 cm. Grazie alla loro facile applicazione è possibile segnalare qualsiasi contesto formando parole e/o unendo vari numeri o pittogrammi. Applicare su una superficie liscia.

GB | Pictogram "Typo" inox adhesive
Pictograms, letters and numbers in stainless steel 0,25 cm "Typo". Easy and fast installation on a slick surface thanks to a double-sided adhesive tape. For the inside and semi-outdoor. Can be combined in order to compose words or series of numbers.

DE | Piktogramme "Typo"
Piktogramme, Buchstaben, Nummer, selbstklebend aus rostfreiem Stahl, 0,25 cm. Dank ihrer leichten Anbringung, ist es möglich beliebige Ereignisse zu symbolisieren wie zum Beispiel ganze Worte, Zahlenreihen oder Piktogramme zu formen.

PO | Pictograma "Typo" em inox auto-adesivo
Pictogramas, letras e números auto-adesivos, fabricados em aço inoxidável de 0,25 cm. Graças à sua fácil colocação, permitem sinalizar qualquer ambiente, formar palavras e/ou unir vários números ou pictogramas. Aplicar sobre uma superfície lisa.

A

letras

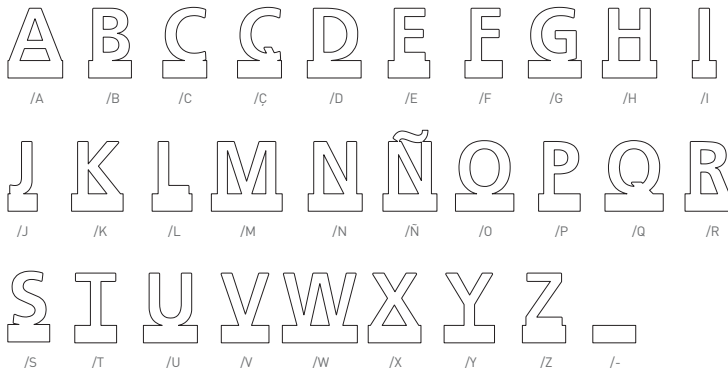

TY/L/... 8,5 x 5,1 0,25



B

num.

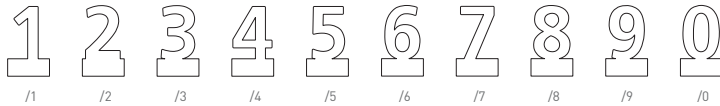

TY/N/... 8,5 x 5,1 0,25



C

pictos

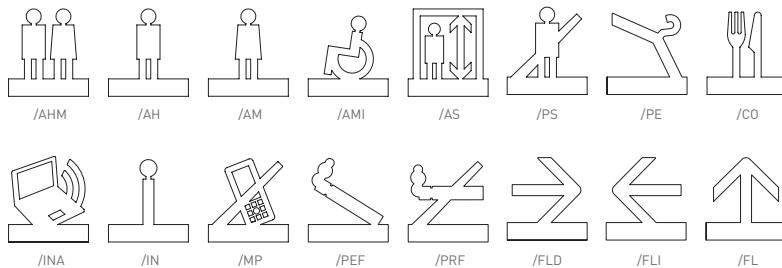

/AHM - Aseo mixto
Mix toilets
/AH - Aseo hombre
Men toilets
/AM - Aseo mujer
Women toilets
/AMI - Aseo minusvál.
Disable

/AS - Ascensor
Lift
/PS - Prohib. paso
No enter
/PE - Guardarropa
Cloakroom
/CO - Comedor
Restaurant

/INA - Inalámbrico
Wireless
/IN - Información
Information
/MP - Móvil prohibido
No mobile phones
/PEF - Permitido fumar
Smoking

/PRF - Prohibido fumar
No smoking
/FLD - Flecha derecha
Right arrow
/FLI - Flecha izquierda
Left arrow
/FL - Flecha
Arrow



TY/P/... 10,6 0,25



SNAP

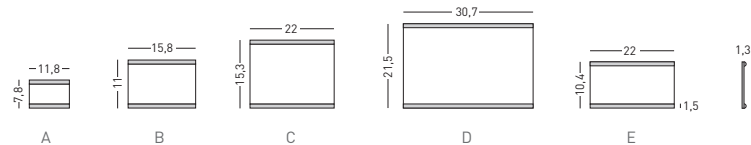
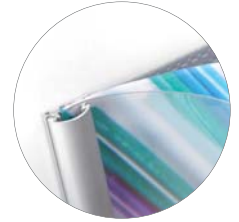

		↕	↔	↕
A	BL/RO/0001	7,4 x 10,5	7,8 x 11,8	1,3
B	BL/RO/0002	10,5 x 14,8	11, x 15,8	1,3
C	BL/RO/0003	14,8 x 21	15,3 x 22	1,3
D	BL/RO/0004	21 x 29,7	21,5 x 30,7	1,3
E	BL/RO/0005	9,9 x 21	10,4 x 22	1,3

ES | Rótulos de aluminio "Snap"

Sistema de señalización de interiores fabricado en perfil de aluminio anodizado plata mate. El doble perfil en forma de marco abatible permite clipar el documento cubierto por un plástico transparente antireflex. Disponible de diversos formatos.

GB | "Snap" aluminium sign

Anodized aluminium inside sign. Double profiled with snap frame to insert a document under an antireflex/UV-stabilized plastic protection. Various sizes available.

FR | Signalétique en aluminium "Snap"

Signalétique d'intérieur en aluminium anodisé "Snap". Double profil, cadre auto clipant pour insérer un document sous plastique transparent anti reflets/anti UV. Divers formats disponibles.

DE | Alu-schilder "Snap"

Innenbeschilderung-System aus silber matt eloxiertem Aluminium. Mit einem Doppel-Profil Klappenrahmen system und einer UV-stabilisierten Antireflex Folie, die das Dokument vor dem Ausbleichen durch die Sonne schützt.

IT | Etichetta in alluminio "Snap"

Sistema di segnaletica da interni fabbricato in profilo d'alluminio anodizzato. Il doppio profilo a cornice ribaltabile permette di clipare il documento coperto da plastica trasparente antiriflesso. Disponibile in diversi formati.

PO | Sinalética em alumínio "Snap"

Sistema de sinalética para interior, fabricado em perfil de alumínio anodizado na cor prata mate. O duplo perfil em forma de "clip", permite fixar o documento, que fica coberto por um plástico transparente anti-reflexo. Disponível em diversos formatos.



SPEEDY

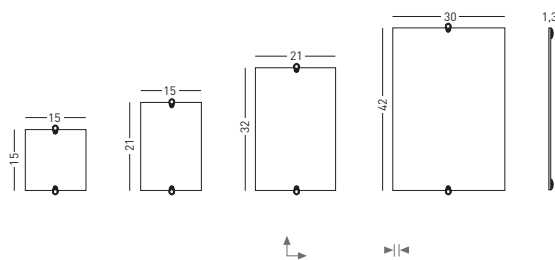

A	BL/RO/0010	15 x 15	1,3
B	BL/RO/0011	15 x 21	1,3
C	BL/RO/0012	21 x 32	1,3
D	BL/RO/0013	30 x 42	1,3

ES | Rótulo "Speedy"

Sistema de señalización de interiores provisto de pinzas de rápida y fácil apertura. El documento se sitúa entre ambas piezas planas de plástico, transparente la delantera, para evitar su manipulación y deterioro. Las pinzas permiten atornillarse a la pared o adhesivarse mediante adhesivos doble cara.

GB | Sign "Speedy"

Interior signage system pole clamps quick and easy opening of "Speedy". The document is placed between two flat pieces of plastic, transparent front, to prevent tampering and deterioration. The forceps allow screwed to the wall by adhesive or double sided adhesives.

FR | Signalétique "Speedy"

Système de signalétique pour l'intérieur avec des pinces à ouverture rapide et facile. Le document est placé entre deux plaques en matière plastique et transparente, afin de prévenir toute altération et/ou détérioration du message ou document. Les pinces sont collées à la paroi par de l'adhésif double face.

DE | "Speedy" System

"Speedy", ein System zum anbringen von Hinweisen mittels Klammern. Einfach und leicht zu öffnen. Das Dokument wird zwischen den zwei Klammern gehalten, die Vorderseite ist transparent. Das System lässt sich anschrauben oder mittels eines zweiseitigen Klebebandes an der Wand befestigen.

IT | Segnaletica "Speedy"

Sistema di segnaletica da interno con una apertura rapida e semplice. Il documento è posto tra due elementi appiattiti in materiale plastico, il frontale è trasparente onde evitare la manomissione ed il deterioramento. Le pinze consentono di applicarlo alla parete mediante adesivo o lateralmente con Bi-adesivo

PO | Sinalética "Speedy"

Sistema de sinalização para interior que funciona através de pinças de fácil e rápida abertura. O documento é colocado entre ambas as peças de plástico transparente para evitar a sua manipulação e deterioração. As pinças são colocadas na parede através de parafusos ou de adesivo dupla face.

PLACAS



	↕	↔
795/A4/	29,7 x 21	0,2
795/A4/F/	29,7 x 21	0,2
795/A4+/-	34,5 x 24,5	0,2
795/A3/	42 x 29,7	0,2
795/A3/F/	42 x 29,7	0,2
795/A3+/-	49 x 34,5	0,2
795/21/	21 x 21	0,2
795/21/F/	21 x 21	0,2
795/10/	10,5 x 29,7	0,2
795/10/F/	10,5 x 29,7	0,2

ES | Señalización normalizada

Placas DIN A4, DIN A3 y cuadradas de 21 x 21 cms. fabricadas en aluminio lacado y serigrafiado según normativa para la señalización de prevención de riesgos laborales. [Real decreto 485/1997 del 14 de Abril] UNE 81-501-81 / UNE 23-033-81 / UNE 23-034-88.

FR | Panneaux signalisation

Panneaux A4, A3 et carrés 21 x 21 cm. en aluminium laqué et sérigraphie conformes aux normes européennes pour la signalisation de sécurité et la santé sur les lieux de travaux [Décret 485/1997 14 avril] UNE 81-501-81 / UNE 23-033-81 / UNE 23-034-88.

IT | Segnaletica di sicurezza

Segnaletica stampata DIN A4, DIN A3 e quadrata 21 x 21 cm. in alluminio laccato stampata per notificare regolamenti, leggi e segnali di prevenzione. [Decreto 485/1997 del 14 Aprile] UNE 81-501-81 / UNE 23-033-81 / UNE 23-034-88.

GB | Attention signs emergency

Printed signs in A4, A3 and squares of 21 x 21 cm. are made with lacquered aluminium printed to notify regulations, laws and prevention awareness. [Decree 485/1997 of April 14th] UNE 81-501-81 / UNE 23-033 81 / UNE 23-034-88.

DE | Rettungszeichen

Hinweisschilder A4, A3 und quadratisch 21 x 21 cm. in lackiertem Aluminium hergestellt. Grüne Serigraphie im Sinne der Sicherheits- und Gesundheitsschutzkennzeichnung am Arbeitsplatz. [Anordnung 485/1997 14 April] UNE 81-501-81.

PO | Sinalética normalizada

Placas DIN A4, DIN A3 e circulares com 21 x 21 cm. fabricadas em alumínio lacado e serigrafiado segundo a normativa de sinalização de prevenção de riscos laborais. UNE 81-501-81 / UNE 23-033-81 / UNE 23-034-88.

A

salida



	<input type="checkbox"/> A3	<input type="checkbox"/> A4	21x21
616	X	X	-
617	X	X	-
623	X	X	-
631	X	X	-
632	X	X	-
633	X	X	-
645	X	X	-

	<input type="checkbox"/> A3	<input type="checkbox"/> A4	21x21
647	-	-	<input type="checkbox"/> X
650	-	-	<input type="checkbox"/> X
651	-	-	<input type="checkbox"/> X
652	-	-	<input type="checkbox"/> X
653	-	-	<input type="checkbox"/> X
654	-	-	10,5 x 29,7

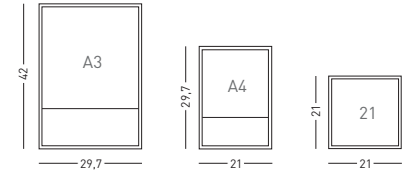

B

extinción



	<input type="checkbox"/> A3	<input type="checkbox"/> A4	21x21
504	X	X	-
510	X	X	-
511	X	X	-
523	X	X	-

	<input type="checkbox"/> A3	<input type="checkbox"/> A4	21x21
524	-	-	<input type="checkbox"/> X
525	-	-	<input type="checkbox"/> X
529	-	-	<input type="checkbox"/> X
530	-	-	<input type="checkbox"/> X

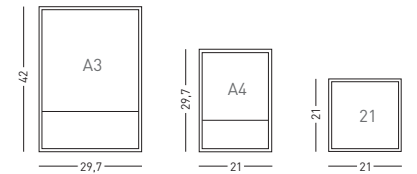

305

C

peligro



	<input type="checkbox"/> A3+	<input type="checkbox"/> A4+	21x21
201	X	X	<input type="checkbox"/> X
203	X	X	<input type="checkbox"/> X
207	X	X	<input type="checkbox"/> X
208	X	X	<input type="checkbox"/> X

	<input type="checkbox"/> A3+	<input type="checkbox"/> A4+	21x21
212	X	X	<input type="checkbox"/> X
228	X	X	<input type="checkbox"/> X
232	X	X	<input type="checkbox"/> X
249	X	X	<input type="checkbox"/> X

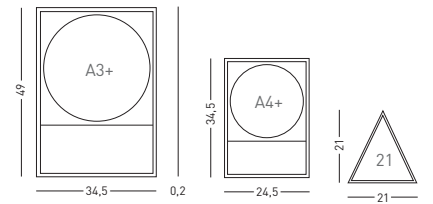

D

prohibición



	<input type="checkbox"/> A3+	<input type="checkbox"/> A4+	21x21
105	X	X	<input type="checkbox"/> X
106	X	X	<input type="checkbox"/> X
111	X	X	<input type="checkbox"/> X
109	X	X	<input type="checkbox"/> X

	<input type="checkbox"/> A3+	<input type="checkbox"/> A4+	21x21
124	X	X	<input type="checkbox"/> X
141	X	X	<input type="checkbox"/> X
607	X	X	<input type="checkbox"/> X
608	X	X	<input type="checkbox"/> X

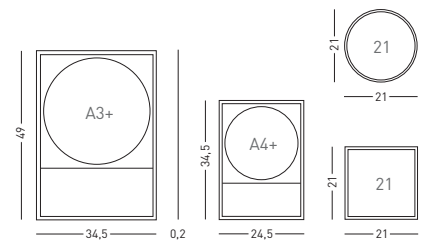

E

obligación



	<input type="checkbox"/> A3+	<input type="checkbox"/> A4+	21x21
301	X	X	<input type="checkbox"/> X
302	X	X	<input type="checkbox"/> X
304	X	X	<input type="checkbox"/> X
305	X	X	<input type="checkbox"/> X

	<input type="checkbox"/> A3	<input type="checkbox"/> A4	21x21
306	-	-	<input type="checkbox"/> X
312	-	-	<input type="checkbox"/> X
1821/S	X	X	<input type="checkbox"/> X
1822/S	X	X	<input type="checkbox"/> X

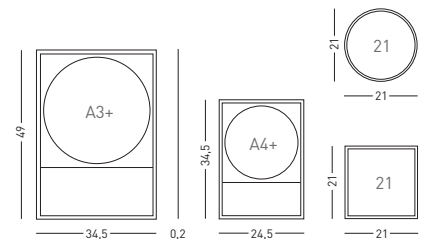

306

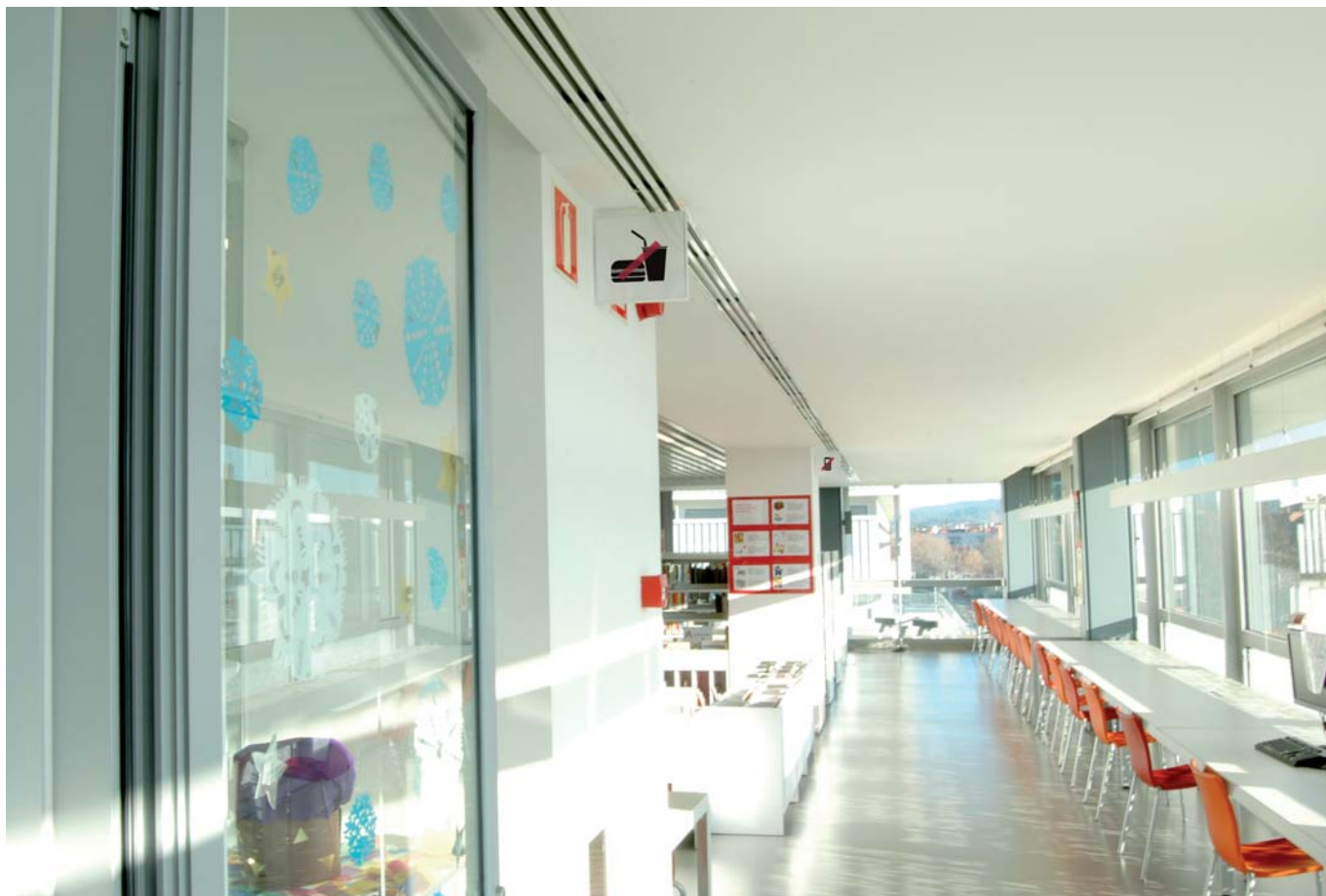

Biblioteca Mira-Sol, Sant Cugat del Vallès (Barcelona)



Rótulo suspendido doble cara (REF. 789/S)

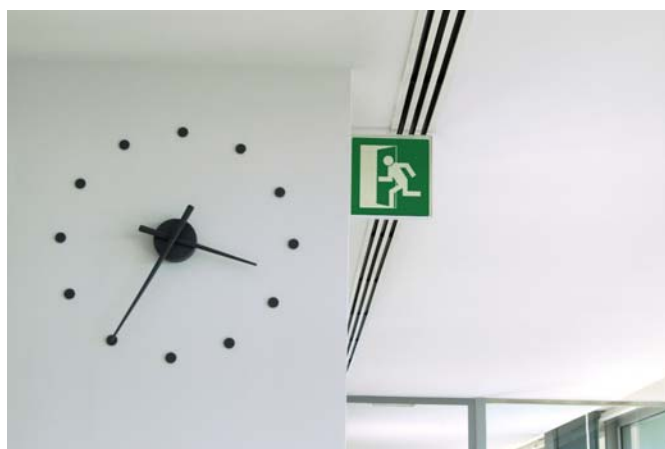

Rótulo proyectado plano (REF. 789/P)

Projects

PS design



Centro Residencial Esclat Marina, Barcelona



Sistema de rotulació MENFIS by Mario Ruiz



Sistema de rotulació MENFIS by Mario Ruiz